

## ACT20X-SDI-HDO-L-S

**Weidmüller Interface GmbH & Co. KG**  
 Klingenbergstraße 26  
 D-32758 Detmold  
 Germany

www.weidmueller.com



The ACT20X-SDI-HDO/2SDI-2HDO valve control modules are controlled from the safe zone on the input side by the switching signals (NPN, PNP) and provide digital outputs to switch actuators (solenoids, alarms) in Ex zone 0. Depending on the module, the output current is limited for the ignition protection groups IIC/IIB to 35 mA or 60 mA (only one channel). Integrated alarm contacts issue an alert in the event of a malfunction; this makes troubleshooting easier and increases system availability. The rail mounted disconnect-switch amplifiers are optionally available in one- or two-channel versions. With 11 mm width per channel, the devices need little space in the electrical cabinet.

### General ordering data

Version	EX signal isolating converter, 1-channel
Order No.	<a href="#">8965400000</a>
Type	ACT20X-SDI-HDO-L-S
GTIN (EAN)	4032248785018
Qty.	1 items

## ACT20X-SDI-HDO-L-S

Weidmüller Interface GmbH &amp; Co. KG

Klingenbergstraße 26  
D-32758 Detmold  
Germany

www.weidmueller.com

## Technical data

## Approvals

Approvals CE; CULUS; DETNORVER; FMEX; FUSAFETY; IECEXKEM; KEMAATEX

Approvals DNVGL;

Approvals



ROHS Conform

UL File Number Search [UL Website](#)

Certificate no. (cULus) E337701

## Dimensions and weights

Depth	113.6 mm	Depth (inches)	4.4724 inch
Height	119.2 mm	Height (inches)	4.6929 inch
Width	22.5 mm	Width (inches)	0.8858 inch
Net weight	170 g		

## Temperatures

Storage temperature	-20 °C...85 °C	Operating temperature	-20 °C...60 °C
Humidity	0...95 % (no condensation)		

## Probability of failure

SIL PAPER	SIL certificate - PDF/ Cert_Weidmueller_070902_P0002_C004_V2R1.pdf (application/pdf)	SIL in compliance with IEC 61508	2
MTBF	175 a		

## Environmental Product Compliance

RoHS Compliance Status	Compliant with exemption
RoHS Exemption (if applicable/known)	7a, 7cl
REACH SVHC	Lead 7439-92-1
SCIP	2f6dd957-421a-46db-a0c2-cf1609156924

## Assembling

Type of mounting	Rail, Snap mounting support rail	Mounting rail	TS 35
Mounting position	horizontal or vertical		

## Input

Number inputs	1	Type	NPN, PNP transistor, switching signal [input safe-side valve component]
Input voltage	≤ 28 V DC, Trigger level low: ≤ 2.0 V DC (NPN), ≤ 8.0 V DC (PNP), Trigger level high: ≥ 4.0 V DC (NPN), ≥ 10.0 V DC (PNP)	Input resistance, voltage	3.5 kΩ

## ACT20X-SDI-HDO-L-S

**Weidmüller Interface GmbH & Co. KG**

 Klingenbergstraße 26  
 D-32758 Detmold  
 Germany

[www.weidmueller.com](http://www.weidmueller.com)

## Technical data

### Output

Type	intrinsically safe circuit, digital, output = input, direct or inverse (configurable)		
Output values	Current	max.	35 mA
	Voltage	min.	12.5 V
	Current	max.	35 mA
	Voltage	min.	13.5 V
	Current	max.	35 mA
	Voltage	min.	14.5 V
Output values	depending on terminal assignment: 12.5 V @ 35 mA / 13.5 V @ 35 mA / 14.5 V @ 35 mA		
Number of outputs, Ex	1		
Residual ripple (current loop)	<40 mVeff		
Output values	depending on terminal assignment		

### Output (Status)

Hysteresis	0.1 mA (switching threshold)	Type	Status relay, 1 NC (voltage-free)
Alarm function	No supply voltage, Device error	Number of alarm outputs	1
Nominal switching voltage	≤ 125 V AC / 110 V DC (safe area) ≤ 32 V AC / 32 V DC (zone 2)	Continuous current	≤ 0.5 A AC / 0.3 A DC (safe zone), ≤ 0.5 A AC / 1 A DC (zone 2)
Power rating	≤ 62.5 VA / 32 W (safe area) ≤ 16 VA / 32 W (Zone 2)		

### General specifications

Type of connection	Screw connection	Humidity	0...95 % (no condensation)
Protection degree	IP20	Supply voltage	19.2...31.2 V DC
Step response time	10 ms	Configuration	With FDT/DTM software, Requires configuration adapter 8978580000 CBX200 USB
Operating altitude	≤ 2000 m		

### Insulation coordination

EMC standards	EN 61326-1	Standards	EN 61010-1
Insulation voltage	2.6 kV (input / output)	Rated voltage	300 V

### Data for Ex applications (ATEX)

ATEX - gas labelling	II (1) G [Ex ia Ga] IIC/IIB/IIA	ATEX - dust labelling	II (1) D [Ex ia Da] IIIC, I (M1) [Ex ia Ma] I
IECEx - gas labelling	Ex ec nC IIC T4 Gc, [Ex ia Ga] IIC/IIB/IIA	Installation location	Device installed in safe area, zone 2

### Connection data

Type of connection	Screw connection	Tightening torque, min.	0.4 Nm
Tightening torque, max.	0.6 Nm	Clamping range, rated connection	2.5 mm <sup>2</sup>
Clamping range, min.	0.25 mm <sup>2</sup>	Clamping range, max.	2.5 mm <sup>2</sup>
Wire connection cross section AWG, min.	AWG 26	Wire connection cross section AWG, max.	AWG 12

## ACT20X-SDI-HDO-L-S

**Weidmüller Interface GmbH & Co. KG**

Klingenbergstraße 26  
D-32758 Detmold  
Germany

www.weidmueller.com

## Technical data

### Guarantee

Time interval	3 years
---------------	---------

### Part description

#### Product description

The ACT20X-SDI-HDO-S solenoid valve switch/alarm transmitter has one input in the non-hazardous area and one output in the hazardous area Zone 0. The device is suitable for switching e.g. magnetic valves or alarm transmitters. The device is available as single-channel or dual-channel version.

#### Features

- Solenoid valve switch / alarm transmitter for the control of solenoids, acoustic alarms and LED's installed in the hazardous area.
- Two variants with 35 mA or 60 mA output current are available in 1-channel or 2-channel versions.
- Configuration and diagnosis via FDT/DTM Software "WI-Manager".
- Selection of direct or inverted function for each channel and the possibility of reducing the output current to the hazardous area to suit the application.
- The device can be mounted in the safe area and in Zone 2 / Division 2 and receive signals from Zone 0, 1, 2, 20, 21 and 22, as well as Class I/II/III, Division 1, Group A-G.
- Extended self diagnostic: Monitoring of error events via the individual status relay.
- LED indication: green and 2 yellow/red front LED's to indicate operation status and malfunction
- 3-way galvanic isolation between input, output and power supply.

### Classifications

ETIM 8.0	EC002653	ETIM 9.0	EC002653
ETIM 10.0	EC002653	ECLASS 14.0	27-21-01-20
ECLASS 15.0	27-21-01-20		

**ACT20X-SDI-HDO-L-S**

**Weidmüller Interface GmbH & Co. KG**  
 Klingenbergstraße 26  
 D-32758 Detmold  
 Germany

**Drawings**

www.weidmueller.com

**Connection diagram**

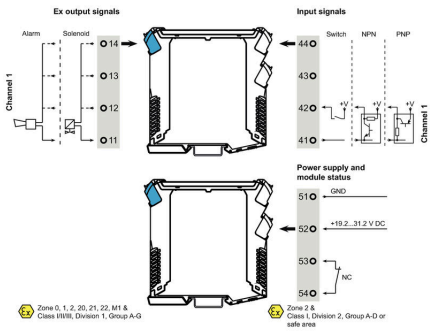

**Application**



**Block diagram**

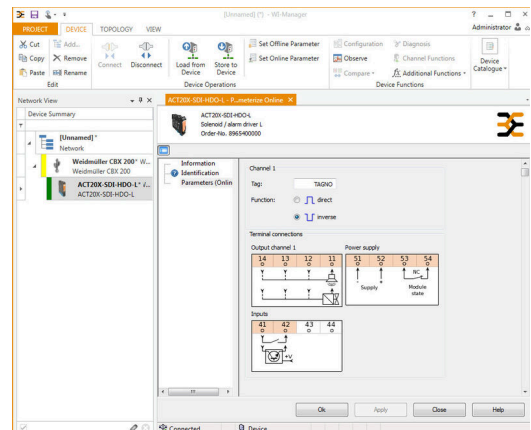
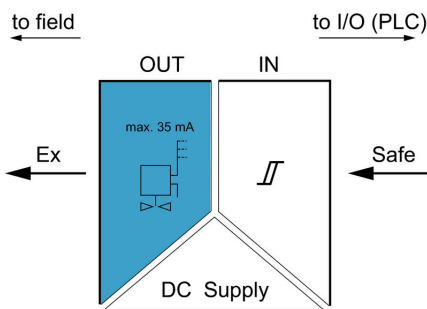

**Derating curve**



**ACT20X-SDI-HDO-L-S**

**Weidmüller Interface GmbH & Co. KG**  
Klingenbergstraße 26  
D-32758 Detmold  
Germany

**Drawings**

[www.weidmueller.com](http://www.weidmueller.com)

**Dimensioned drawing**

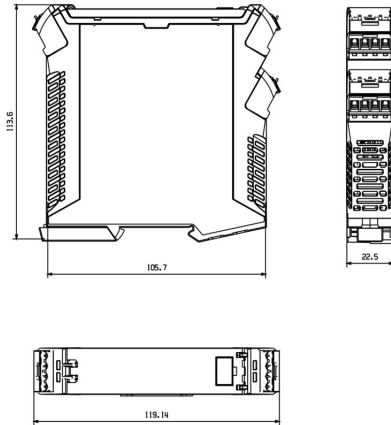

Removable terminals with coding