

ACT20P-TMR-RTI-P

Weidmüller Interface GmbH & Co. KG
Klingenbergstraße 26
D-32758 Detmold
Germany

www.weidmueller.com

Product image, Similar to illustration



ACT20P: The flexible solution

- Precise and highly functional signal converters
- Release levers simplify handling

General ordering data

Version	Limit value monitoring, Input : Temperature, PT100, Output : 2 x relays
Order No.	7760054352
Type	ACT20P-TMR-RTI-P
GTIN (EAN)	4050118559453
Qty.	1 items

ACT20P-TMR-RTI-P

Weidmüller Interface GmbH & Co. KG

Klingenbergstraße 26

D-32758 Detmold

Germany

www.weidmueller.com

Technical data

Approvals

Approvals



ROHS	Conform
UL File Number Search	UL Website
Certificate no. (cULus)	E338066

Dimensions and weights

Depth	114.3 mm	Depth (inches)	4.5 inch
Height	127.1 mm	Height (inches)	5.0039 inch
Width	22.5 mm	Width (inches)	0.8858 inch
Net weight	140 g		

Temperatures

Storage temperature	-40 °C...85 °C	Operating temperature	-25 °C...65 °C
Humidity	5-95% relative humidity, Tu = 40°C, without condensation		

Environmental Product Compliance

RoHS Compliance Status	Compliant with exemption
RoHS Exemption (if applicable/known)	7a, 7cl
REACH SVHC	Lead 7439-92-1
SCIP	2f6dd957-421a-46db-a0c2-cf1609156924

Input

Sensor	PT100 (2-/3-/4- wire), PTC resistor (2- wire)	Number inputs	1
Temperature input range	Configurable, PT100: -200°C...850 °C	Resistance	PTC: 0...4 kΩ

Output (digital)

Rated switching current	5 A	Number of digital outputs	1
Max. switching voltage, AC	250 V	Max. switching voltage, DC	30 V
Type	2 x 1 - or 1 x 2 changeover contact relay	Alarm function	Alarm range: -200...850 °C, Limit values: high, low, window, Hysteresis: 2 °C (adjustable), Window range: min. 20 °C, Alarm delay: 0...10 s

General data

Accuracy	0.2% FSR, ≤ 2 °C (PT100), ≤ 8 Ω (PTC)	Protection degree	IP20
Supply voltage	20...264 VUC	Long-term drift	0.1 % / 10.000 h
Step response time	≤ 500 ms	Mounting rail	TS 35
Power consumption	≤ 100 mA @ 24 VDC, ≤ 120mA @ 24V AC	Temperature coefficient	≤ 100 ppm/K
Nominal power consumption	3 VA	Configuration	With FDT/DTM software, Requires configuration

ACT20P-TMR-RTI-P

Weidmüller Interface GmbH & Co. KG

Klingenbergstraße 26
D-32758 Detmold
Germany

www.weidmueller.com

Technical data

adapter 8978580000
CBX200 USB

Operating altitude ≤ 2000 m

Insulation coordination

Impulse withstand voltage	4 kV (1.2/50 µs)	EMC standards	EN 61326-1
Surge voltage category	III	Pollution severity	2
Galvanic isolation	3-way isolator, between input/output/supply	Insulation voltage	2 kV (Input /Output), 1 min, 50 Hz
Rated voltage	300 V		

Data for Ex applications (ATEX)

Marking	II 3 G Ex ec nC IIC T5 Gc	IECEx - gas labelling	Ex ec nC IIC T5 Gc
---------	---------------------------	-----------------------	--------------------

Connection data

Type of connection	PUSH IN	Tightening torque, min.	0.4 Nm
Tightening torque, max.	0.6 Nm	Clamping range, rated connection	2.5 mm ²
Clamping range, min.	0.5 mm ²	Clamping range, max.	2.5 mm ²
Wire connection cross section AWG, min.	AWG 26	Wire connection cross section AWG, max.	AWG 14
Wire cross-section, solid, min.	0.2 mm ²	Wire cross-section, solid, max.	2.5 mm ²
Wire connection cross section, finely stranded, min.	0.2 mm ²	Wire connection cross section, finely stranded, max.	2.5 mm ²
Wire connection cross-section, finely stranded with wire-end ferrules DIN 46228/4, min.	0.2 mm ²	Wire connection cross-section, finely stranded with wire-end ferrules DIN 46228/4, max.	2.5 mm ²

Part description

Product description	<p>The ACT20P-TMR-RTI-S device records temperature sensor signals (Pt100, PTC). It has two independent relay outputs which emit an alarm when levels exceed or fall below pre-set temperature limits.</p> <p>Features</p> <ul style="list-style-type: none"> • Configuration and monitoring are performed via FDT/DTM-Software „WI-Manager“. • Operational status and relay status indicated by front panel LEDs. • 4-way galvanic isolation between input, output and power supply.
---------------------	---

Classifications

ETIM 8.0	EC002919	ETIM 9.0	EC002919
ETIM 10.0	EC002919	ECLASS 14.0	27-21-01-29
ECLASS 15.0	27-21-01-29		

ACT20P-TMR-RTI-P

Weidmüller Interface GmbH & Co. KG
 Klingenbergstraße 26
 D-32758 Detmold
 Germany

www.weidmueller.com

Drawings

Connection diagram



Dimensioned drawing, Similar to illustration

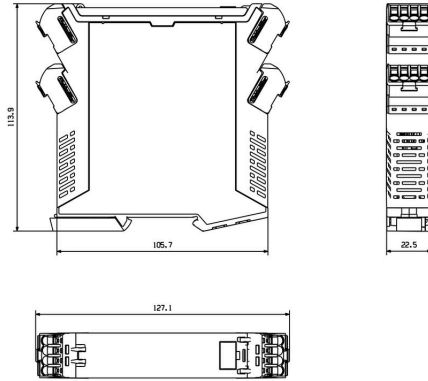

Over-temperature alarm (O)

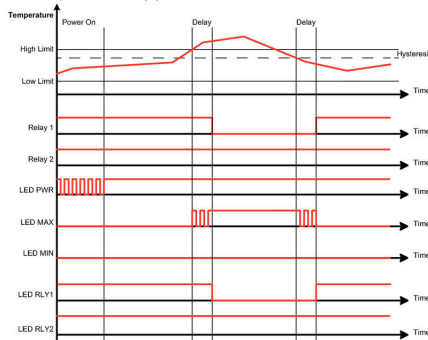

Under-temperature alarm (U)

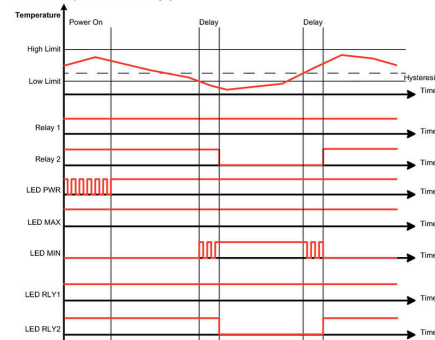

Temperature window alarm (W)

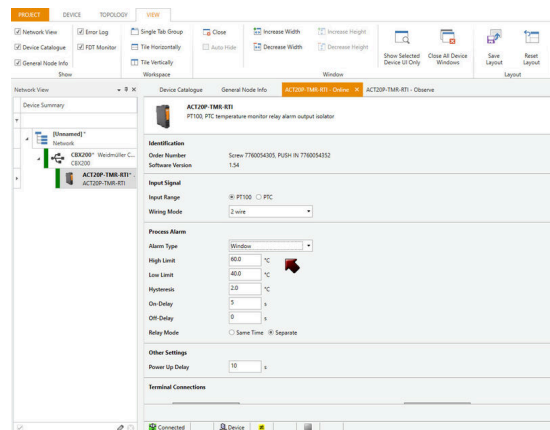
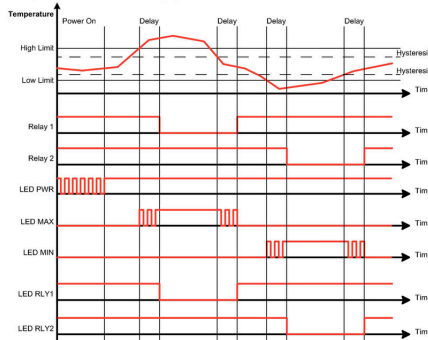

screenshot of configuration with FDT2 / DTM software

ACT20P-TMR-RTI-P

Weidmüller Interface GmbH & Co. KG
Klingenbergstraße 26
D-32758 Detmold
Germany

www.weidmueller.com

Drawings



screenshot of "observe" with FDT2 / DTM software