

EPAK-VMR-1PH-300-24V

Weidmüller Interface GmbH & Co. KG
 Klingenbergstraße 26
 D-32758 Detmold
 Germany

www.weidmueller.com



The analogue converters of the EPAK series are characterised by their compact design. The wide range of functions available with this series of analogue converters make them suitable for applications which do not require international approvals.

Properties:

- Safe isolation, conversion and monitoring of your analogue signals
- Configuration of the input and output parameters directly on the device via DIP switches
- No international approvals
- High interference resistance

General ordering data

Version	Limit value monitoring, Input: single-phase voltage, Input : 1 phase, Output : Relay
Order No.	7760054244
Type	EPAK-VMR-1PH-300-24V
GTIN (EAN)	6944 169733765
Qty.	1 items

EPAK-VMR-1PH-300-24V

Weidmüller Interface GmbH & Co. KG
 Klingenbergstraße 26
 D-32758 Detmold
 Germany

www.weidmueller.com

Technical data

Approvals

Approvals



ROHS Conform

Dimensions and weights

Depth	89 mm	Depth (inches)	3.5039 inch
Height	100 mm	Height (inches)	3.937 inch
Width	17.5 mm	Width (inches)	0.689 inch
Length	100 mm	Length (inches)	3.937 inch
Net weight	80 g		

Temperatures

Storage temperature	-40 °C...85 °C	Operating temperature	-40 °C...60 °C
Humidity at operating temperature	0...95 % (no condensation)		

Probability of failure

SIL in compliance with IEC 61508 None

Environmental Product Compliance

RoHS Compliance Status	Compliant with exemption
RoHS Exemption (if applicable/known)	7a, 7cl
REACH SVHC	Lead 7439-92-1
SCIP	6a722fc5-2d22-41b4-9544-5b95e45a4b77

Input

Input frequency	40...60 Hz	Input voltage	U1: 30 … 300 VAC/ DC, U2: 6 … 60 VAC/DC
Input signal	DC, AC (sine)	Input resistance, voltage	1 MΩ±5%

Output

Number of outputs 1

Output (digital)

Rated switching current	3 A	Number of digital outputs	1
Max. switching voltage, AC	250 V	Max. switching voltage, DC	30 V
Type	Relay, 1 CO contact	Alarm function	Surge voltage, Undervoltage, Alarm range: 10%...100% *IN, Hysteresis: 5%*UN (fixed), Alarm delay: 0...10 s

EPAK-VMR-1PH-300-24V

Weidmüller Interface GmbH & Co. KG
 Klingenbergstraße 26
 D-32758 Detmold
 Germany

www.weidmueller.com

Technical data

General data

Repeat accuracy	2 % *Urated voltage	Accuracy	Setting tolerance: 5% of UN, Transmission tolerance: 5% of UN
Protection degree	IP20	Supply voltage	18...30 VDC
Step response time	≤ 200 ms (10...90%)	Power consumption	<60 mA @24 VDC, <9 mA @230 VAC
Temperature coefficient	≤ 250 ppm/K of final value, ± 250 ppm/K, 350 ppm/K	Nominal power consumption	1.5 VA
Configuration	DIP switch and potentiometer	Operating altitude	≤ 2000 m

Insulation coordination

Impulse withstand voltage	4 kV (1.2/50 µs)	EMC standards	IEC 61000-6-2, IEC 61000-6-4, EN 61326
Surge voltage category	III	Pollution severity	2
Galvanic isolation	between input/output/supply/relay	Insulation voltage	2.2 kVAC, 1 min, 50 Hz
Rated voltage	300 V ACrms		

Connection data

Type of connection	Screw connection	Tightening torque, min.	0.4 Nm
Tightening torque, max.	0.6 Nm	Clamping range, rated connection	2 mm ²
Clamping range, min.	0.5 mm ²	Clamping range, max.	2 mm ²
Wire connection cross section AWG, min.	AWG 30	Wire connection cross section AWG, max.	AWG 14

Classifications

ETIM 8.0	EC002654	ETIM 9.0	EC002654
ETIM 10.0	EC002654	ECLASS 14.0	27-21-01-22
ECLASS 15.0	27-21-01-22		

EPAK-VMR-1PH-300-24V

Weidmüller Interface GmbH & Co. KG
 Klingenbergstraße 26
 D-32758 Detmold
 Germany

www.weidmueller.com

Drawings

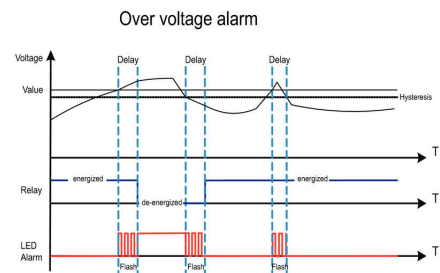
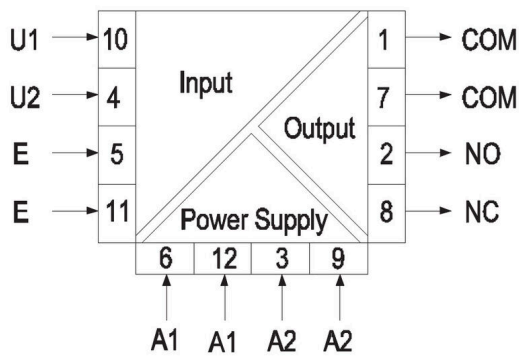
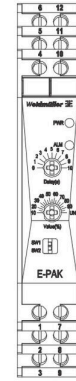
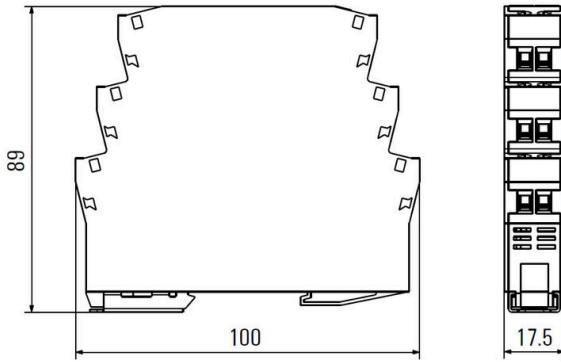

Under voltage alarm

