

TRP 24VDC ACT PB

Weidmüller Interface GmbH & Co. KG
 Klingenbergstraße 26
 D-32758 Detmold
 Germany

www.weidmueller.com

Product image

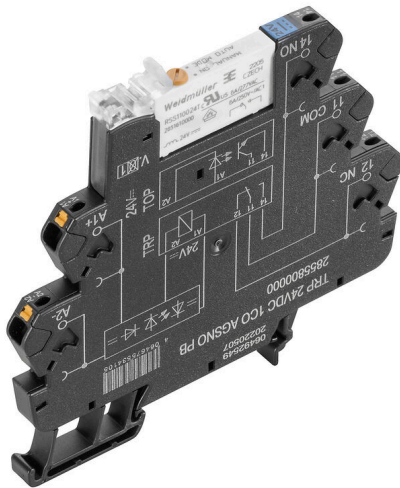

Similar to illustration

- 1 NO contact
- Contact connection: Screw and PUSH IN
- Contact material: AgSnO
- Input voltages 24 V DC with coloured marking: DC: blue
- Wiring optimized 24 V DC actuator version: Bridgeable, potential-free connection in the output (CC)
- Version with lockable test button for manual switching

General ordering data

Version	TERMSERIES, Relay module, Number of contacts: 1, NO contact AgSnO, Rated control voltage: 24 V DC $\pm 20\%$, Continuous current: 6 A, PUSH IN, Test button available: Yes
Order No.	2855840000
Type	TRP 24VDC ACT PB
GTIN (EAN)	4064675534143
Qty.	10 items

TRP 24VDC ACT PB

Weidmüller Interface GmbH & Co. KG

Klingenbergstraße 26

D-32758 Detmold

Germany

www.weidmueller.com

Technical data

Approvals

Approvals



ROHS Conform

UL File Number Search [UL Website](#)

Certificate no. (cULus) E141197

Dimensions and weights

Depth	87.8 mm	Depth (inches)	3.4567 inch
Height	89.4 mm	Height (inches)	3.5197 inch
Width	6.4 mm	Width (inches)	0.252 inch
Net weight	28.44 g		

Temperatures

Storage temperature	-40 °C...85 °C	Ambient temperature	-40 °C...60 °C
Operating temperature		Humidity	5-95% relative humidity, Tu = 40°C, without condensation

Environmental Product Compliance

RoHS Compliance Status	Compliant with exemption
RoHS Exemption (if applicable/known)	7a, 7cl
REACH SVHC	Lead 7439-92-1
SCIP	9e2cbc49-76d9-4611-b8ec-5b4f549a0aa9

Rated data UL

Ambient temperature (operational), max.	60 °C	Output current derating (ohmic)	6 A @ 50 °C, 5 A @ 60 °C
Connection cross-section AWG, min.	AWG 26	Connection cross-section AWG, max.	AWG 14
Type of conductor	rigid copper conductor, flexible copper conductor	Pollution severity level	2

Control side

Rated control voltage	24 V DC \pm 20 %	Rated current DC	11.5 mA
Power rating	280 mW	Status indicator	Green LED
Protective circuit	Free-wheeling diode, Reverse polarity protection	Coil voltage of the replacement relay deviating from the rated control voltage	No
Coil voltage of the replacement relay	24 V DC		

Load side

Rated switching voltage	250 V AC	Continuous current	6 A
Max. switching frequency at rated load	0.1 Hz	Max. switching voltage, AC	250 V
Max. switching voltage, DC	250 V	Inrush current	30 A / 20 ms
AC switching capacity (resistive), max.	1500 VA	DC switching capacity (resistive), max.	144 W @ 24 V
Switch-on delay	\leq 12 ms	Switch-off delay	\leq 12 ms
Contact type	1 NO contact (AgSnO)	Mechanical service life	10 x 10 ⁶ switching cycles
Min. switching power	1 mA @ 24 V, 10 mA @ 12 V, 100 mA @ 5 V		

TRP 24VDC ACT PB

Weidmüller Interface GmbH & Co. KG

Klingenbergstraße 26

D-32758 Detmold

Germany

www.weidmueller.com

Technical data

General data

Operating altitude	≤ 2000 m, above sea level	
Mounting rail	TS 35	
Test button available	Yes	
Version of test button	Lockable test button	
Colour	black	
UL94 flammability rating component	Component	Housing
	UL94 flammability rating	V-0
	Component	Retaining clip
	UL94 flammability rating	V-0
	Component	Pusher
	UL94 flammability rating	V-0

Insulation coordination

Rated voltage	300 V	Pollution severity	2
Surge voltage category	III	Clearance and creepage distances for control side - load side	≥ 6 mm
Dielectric strength for control side - load side	3.51 kVeff / 1 min.	Type of isolation at input and output	reinforced insulation
Dielectric strength of open contact	1 kVeff / 1 min	Dielectric strength to mounting rail	4 kVeff / 1 Min.
Impulse withstand voltage	6 kV (1.2/50 µs)	Protection degree	IP20

Further details of approvals / standards

Certificate no. (cULus)	E141197
-------------------------	---------

Connection data

Wire connection method	PUSH IN	Stripping length, rated connection	9 mm
Clamping range, rated connection	1.5 mm ²	Clamping range, min.	0.14 mm ²
Clamping range, max.	2.5 mm ²	Wire connection cross section AWG, min.	AWG 26
Wire connection cross section AWG, max.	AWG 14	Wire cross-section, solid, min.	0.14 mm ²
Wire cross-section, solid, max.	1.5 mm ²	Wire cross-section, solid, min. (AWG)	AWG 26
Wire cross-section, solid, max. (AWG)	AWG 16	Wire connection cross section, finely stranded, min.	0.14 mm ²
Wire connection cross section, finely stranded, max.	2.5 mm ²	Wire cross-section, finely stranded, min. (AWG)	AWG 26
Wire cross-section, finely stranded, max. (AWG)	AWG 14	Wire connection cross-section, finely stranded with wire-end ferrules DIN 46228/4, min.	0.14 mm ²
Wire connection cross-section, finely stranded with wire-end ferrules DIN 46228/4, max.	1.5 mm ²	Conductor cross-section, flexible, AEH (DIN 46228-1), min.	0.14 mm ²
Conductor cross-section, flexible, AEH (DIN 46228-1), max.	1.5 mm ²	Blade size	0.4 x 2.0 mm

Classifications

ETIM 8.0	EC001437	ETIM 9.0	EC001437
ETIM 10.0	EC001437	ECLASS 14.0	27-37-16-01
ECLASS 15.0	27-37-16-01		

Drawings

Wiring diagram

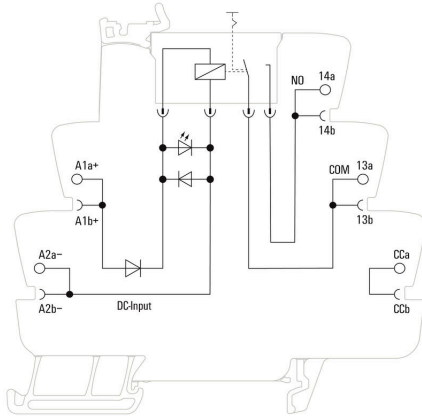

Graph



DC load limit curve Resistive load

Graph



Electrical service life 230 V AC resistive load 230 V AC resistive load

Derating curve

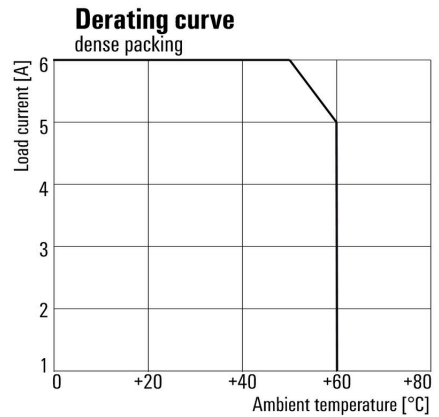

Drawings

Dimensional drawing

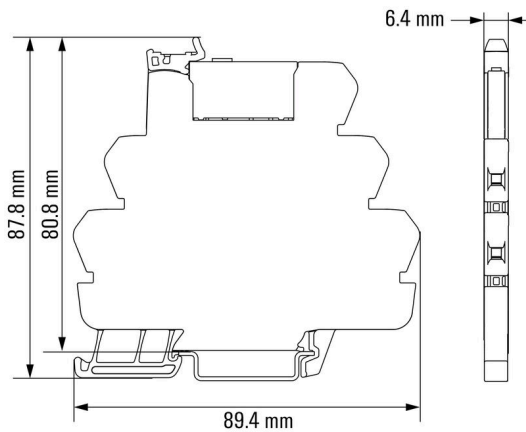

Miscellaneous

Function of test button

Mode is selected by rotating the orange switch.
 The test button can be rotated endlessly.
 The groove on the top shows the selected mode.

View from the top:



Auto Mode:

Relay contact is controlled by the coil.



Manual ON:

Relay is manually switch on without applied coil voltage.
 - NO contact is closed

Miscellaneous

Recommended screwdriver for test button

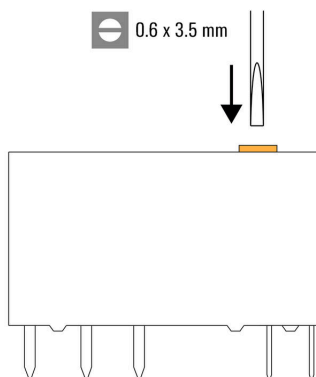

Miscellaneous

Type code TERMSERIES electromechanical relay versions



Type codes

**Space requirement for an 8-channel system
 with a standard TERMSERIES 1CO relay**

Example of output wiring to show the difference in 8 loads to be wired:

Result width = 8 x 5.1 mm (2-pole terminal block) + 1 x 2.1 mm (end plate)
 + 8 x 6.4 mm (TRP 24VDC 1CO) + 3 x 8.0 mm (end bracket) = 118.1 mm



Space requirement top view:



**Space requirement for an 8-channel system
 with TERMSERIES ACT version relays and supply terminals**

Example of output wiring to show the difference in 8 loads to be wired:

Result width = 1 x 6.4 mm (TRP SUPPLY) + 8 x 6.4 mm (TRP 24VDC ACT)
 + 2 x 8.0 mm (end bracket) = 73.6 mm



Space requirement top view:

