

TRPL 24VUC 2CO

Weidmüller Interface GmbH & Co. KG

Klingenbergstraße 26

D-32758 Detmold

Germany

www.weidmueller.com



The all-rounder. Compact relay modules, 12.8 mm width with extensive accessories, maximum vibration resistance, and unlimited cross-connection possibilities.

- 2 CO contacts
- Contact material: AgNi
- Integrated status LED for easy function testing
- Unique multi-voltage input from 12 to 60 V UC and 24 to 230 V UC
- Input voltages from 5 V DC to 230 V UC with colored markings: AC: red, DC: blue, UC: white

General ordering data

Version	TERMSERIES-compact, Relay module, Number of contacts: 2, x 1 CO Contact AgNi, Rated control voltage: 24 V UC $\pm 10\%$, Continuous current: 6 A, PUSH IN, Test button available: No
Order No.	2773990000
Type	TRPL 24VUC 2CO
GTIN (EAN)	4064675037767
Qty.	10 items

TRPL 24VUC 2CO

Weidmüller Interface GmbH & Co. KG

Klingenbergstraße 26

D-32758 Detmold

Germany

www.weidmueller.com

Technical data

Approvals

Approvals



UL File Number Search [UL Website](#)
 Certificate no. (cULus) E141197

Dimensions and weights

Depth	62.5 mm	Depth (inches)	2.4606 inch
Height	89.4 mm	Height (inches)	3.5197 inch
Width	12.8 mm	Width (inches)	0.5039 inch
Net weight	53.5 g		

Temperatures

Storage temperature	-40 °C...85 °C	Ambient temperature	-40 °C...60 °C
Operating temperature		Humidity	5-85% relative humidity, Tu = 40°C, without condensation

Environmental Product Compliance

RoHS Compliance Status	Compliant with exemption
RoHS Exemption (if applicable/known)	7a, 7cl
REACH SVHC	Lead 7439-92-1
SCIP	75e5f661-708e-44b0-9fc2-4f6c675b3b71

Rated data UL

Connection cross-section AWG, min.	AWG 26	Connection cross-section AWG, max.	AWG 14
Type of conductor	flexible copper conductor, rigid copper conductor	Pollution severity level	2

Control side

Rated control voltage	24 V UC ± 10 %	Rated current AC	26 mA
Rated current DC	16 mA	Power rating	0.6 VA / 0.35 W
Coil resistance	3388 Ω ± 10 %	Status indicator	Green LED
Protective circuit	Rectifier		

Load side

Rated switching voltage	250 V AC	Continuous current	6 A
Max. switching frequency at rated load	0.1 Hz	Max. switching voltage, AC	250 V
Max. switching voltage, DC	250 V	Inrush current	20 A / 20 ms
AC switching capacity (resistive), max.	1500 VA	DC switching capacity (resistive), max.	144 W @ 24 V
Contact type	2 x 1 CO Contact (AgNi)	Mechanical service life	5 x 10 ⁶ switching cycles
Min. switching power	1 mA @ 24 V, 10 mA @ 12 V, 100 mA / 5 V		

General data

Operating altitude	≤ 2000 m, above sea level	Mounting rail	TS 35
Test button available	No	Colour	black

TRPL 24VUC 2CO

Weidmüller Interface GmbH & Co. KG

Klingenbergstraße 26
D-32758 Detmold
Germany

www.weidmueller.com

Technical data

Insulation coordination

Pollution severity	2	Surge voltage category	III
Clearance and creepage distances for control side - load side	≥ 6 mm	Dielectric strength for control side - load side	4 kVeff / 1 Min.
Type of isolation at input and output	reinforced insulation	Dielectric strength of neighbouring contacts	4 kVeff / 1 min
Type of isolation at neighbouring contacts	reinforced insulation	Dielectric strength of open contact	1 kVeff / 1 min
Dielectric strength to mounting rail	4 kVeff / 1 Min.	Impulse withstand voltage	6 kV (1.2/50 µs)
Protection degree	IP20		

Further details of approvals / standards

Certificate no. (cULus)	E141197
-------------------------	---------

Connection data

Wire connection method	PUSH IN	Stripping length, rated connection	9 mm
Clamping range, rated connection	1.5 mm ²	Clamping range, min.	0.14 mm ²
Clamping range, max.	2.5 mm ²	Wire connection cross section AWG, min.	AWG 26
Wire connection cross section AWG, max.	AWG 14	Wire cross-section, solid, min.	0.5 mm ²
Wire cross-section, solid, max.	1.5 mm ²	Wire cross-section, solid, min. (AWG)	AWG 26
Wire cross-section, solid, max. (AWG)	AWG 14	Wire connection cross section, finely stranded, min.	0.35 mm ²
Wire connection cross section, finely stranded, max.	2.5 mm ²	Wire cross-section, finely stranded, min. (AWG)	AWG 26
Wire cross-section, finely stranded, max. (AWG)	AWG 14	Wire connection cross-section, finely stranded with wire-end ferrules DIN 46228/4, min.	0.14 mm ²
Wire connection cross-section, finely stranded with wire-end ferrules DIN 46228/4, max.	1.5 mm ²	Conductor cross-section, flexible, AEH (DIN 46228-1), min.	0.5 mm ²
Conductor cross-section, flexible, AEH (DIN 46228-1), max.	1.5 mm ²	Blade size	0.6 x 3.5 mm

Classifications

ETIM 8.0	EC001437	ETIM 9.0	EC001437
ETIM 10.0	EC001437	ECLASS 14.0	27-37-16-01
ECLASS 15.0	27-37-16-01		

TRPL 24VUC 2CO

Weidmüller Interface GmbH & Co. KG
 Klingenbergstraße 26
 D-32758 Detmold
 Germany

www.weidmueller.com

Drawings

Similar to illustration



Wiring diagram

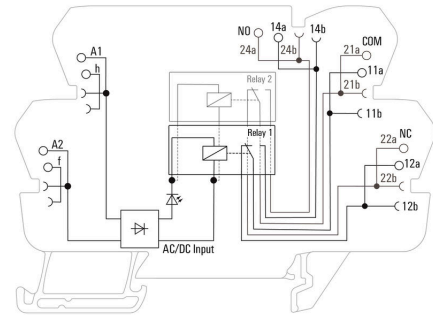

*The switch controls two Relays

Graph



DC load limit curve Resistive load

Graph

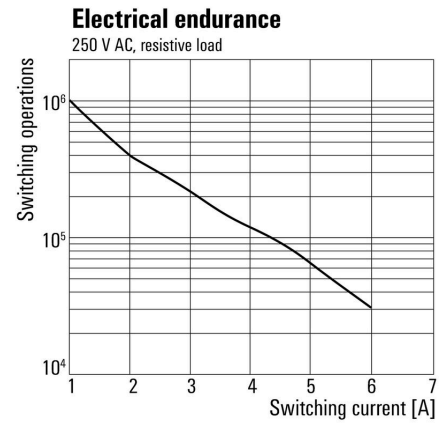

Electrical service life 230 V AC resistive load

Dimensional drawing



Type code electromechanical relay



Type codes