

## VPU AC II US 3+1 R 240/50

**Weidmüller Interface GmbH & Co. KG**  
 Klingenbergstraße 26  
 D-32758 Detmold  
 Germany

www.weidmueller.com

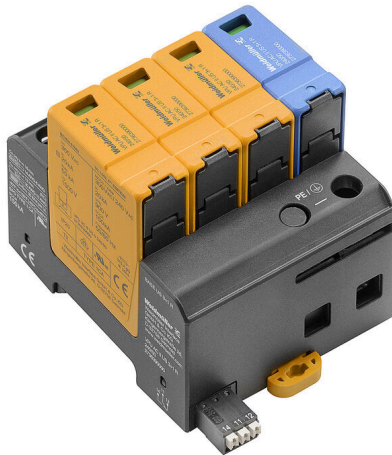

Picture similar

- compact SPD to install in application by NFPA 79
- no additional overcurrent protection devices needed
- short circuit current rating (SCCR) up to 200 kA
- tested according to IEC/EN 61643-11 and UL 1449 4.Ed

### General ordering data

Version	Surge voltage arrester, Low voltage, Surge protection, with remote contact, TN-C-S, TN-S, TT, IT with N, IT without N
Order No.	<a href="#">2736390000</a>
Type	VPU AC II US 3+1 R 240/50
GTIN (EAN)	4050118825787
Qty.	1 items

## VPU AC II US 3+1 R 240/50

**Weidmüller Interface GmbH & Co. KG**  
 Klingenbergstraße 26  
 D-32758 Detmold  
 Germany

www.weidmueller.com

## Technical data

## Approvals

Approvals



ROHS Conform  
 UL File Number Search [UL Website](#)  
 Certificate no. (cULus) E354261

## Dimensions and weights

Depth	68 mm	Depth (inches)	2.6772 inch
Depth including DIN rail	76 mm	Height	104.5 mm
Height (inches)	4.1142 inch	Width	72 mm
Width (inches)	2.8346 inch	Mounting dimension - height	75 mm
Net weight	458 g		

## Temperatures

Storage temperature	-40 °C...85 °C	Ambient temperature	-40 °C...85 °C
Operating temperature	-40 °C...85 °C	Humidity	5 - 95% rel. humidity

## Environmental Product Compliance

RoHS Compliance Status Compliant without exemption  
 REACH SVHC No SVHC above 0.1 wt%

## Rated data UL

Ambient temperature (operational), max.	85 °C	Rated Voltage UN	240 V
VPR (N-PE)	1000 V	MCOV (L-PE)	300 V
MCOV (N-PE)	305 V	SCCR	150 kA
In	20 kA	Category	SPD TYPE 1
Connection cross-section AWG, min.	AWG 14	Connection cross-section AWG, max.	AWG 6
Ambient temperature (operational), min.	-40 °C	MODE	all modes
VPR (L-L)	1800 V	VPR (L-N)	900 V
VPR (L-PE)	1000 V	Voltage type	AC
UL Energy Networks	3-phase WYE		

## Connection data, remote alert

Cross-section for connected wire, solid core, min.	0.25 mm <sup>2</sup>	Stripping length	12 mm
Cross-section for connected wire, solid core, max. (AWG)	AWG 10	Connection type	PUSH IN
Cross-section for connected wire, solid core, max.	1.5 mm <sup>2</sup>	Cross-section for connected wire, solid core, min. (AWG)	AWG 30

## General data

Optical function display	green = OK; red = arrester is defective - replace	Segment	Power distribution
Version	Surge protection, with remote contact	Design	Installation housing; 4TE, Insta IP 20
UL 94 flammability rating	V-0	Colour	orange, black, blue
Protection degree	IP20 in installed state	Mounting rail	TS 35

## VPU AC II US 3+1 R 240/50

**Weidmüller Interface GmbH & Co. KG**

Klingenbergstraße 26  
D-32758 Detmold  
Germany

www.weidmueller.com

## Technical data

Operating altitude ≤ 4000 m

### Insulation coordination acc. to EN 50178

Surge voltage category	III	Pollution severity	2
------------------------	-----	--------------------	---

### Rated data IEC / EN

Number of poles	4	Leakage current at $U_n$	1 $\mu$ A
Signalling contact	250 V 1A 1CO	Rated voltage (AC)	240 V
Low voltage network	TN-C-S, TN-S, TT, IT with N, IT without N	Protection level Up at IN (N-PE)	≤ 1.5 kV
Voltage type	AC	Temporary surge voltage (over-voltage) - TOV	337 V
Fuse protection	No Fuse necessary ≤315 A gG, 250 A gG @50 kA I <sub>sc</sub> cr, 315 A gG @25 kA I <sub>sc</sub> cr	Response time / fallback time	≤ 25 ns
Frequency range, max.	60 Hz	Frequency range, min.	50 Hz
Standards	IEC 61643-11, EN 61643-11, UL 1449, NFPA 79	Requirements class, acc. to EN 61643-11	T2, T3
Requirements category acc. to IEC 61643-11	Type II	Max. continuous voltage, $U_c$ (AC)	300 V
Max. continuous voltage, $U_c$ (N-PE)	305 V	Mains voltage	230 V / 400 V
Discharge current $I_{max}$ (8/20 $\mu$ s) N-PE	65 kA	Discharge current $I_n$ (8/20 $\mu$ s) N-PE	40 kA
Energy coordination (≤10 m)	Type II, Type III	Discharge current $I_n$ (8/20 $\mu$ s) wire-PE	20 kA
Discharge current $I_{max}$ (8/20 $\mu$ s) wire-PE	50 kA	SPD type	T2
Protection level Up at IN (L/N-PE)	≤ 1500 V	Short-circuit current rating I <sub>SCCR</sub>	50 kA
Follow-on current extinguishing capability $I_{fi}$	Follow current need not be taken into account	Integrated back-up fuse	No

### Connection data

Stripping length	18 mm	Wire connection method	Screw connection
Type of connection	Screw connection	Stripping length, rated connection	18 mm
Tightening torque, min.	3 Nm	Tightening torque, max.	4.5 Nm
Clamping range, rated connection	16 mm <sup>2</sup>	Clamping range, min.	1.5 mm <sup>2</sup>
Clamping range, max.	35 mm <sup>2</sup>	Wire connection cross section AWG, min.	AWG 16
Wire connection cross section AWG, max.	AWG 2	Wire cross-section, solid, min.	1.5 mm <sup>2</sup>
Wire cross-section, solid, max.	35 mm <sup>2</sup>	Wire connection cross section, finely stranded, min.	1.5 mm <sup>2</sup>
Wire connection cross section, finely stranded, max.	25 mm <sup>2</sup>	Conductor cross-section, flexible, AEH (DIN 46228-1), min.	2.5 mm <sup>2</sup>
Conductor cross-section, flexible, AEH (DIN 46228-1), max.	35 mm <sup>2</sup>	Connection cross-section, stranded, min.	1.5 mm <sup>2</sup>
Connection cross-section, stranded, max.	35 mm <sup>2</sup>		

### Electrical data

Voltage type	AC
--------------	----

### General data

Number of poles	4	Protection degree	IP20 in installed state
Colour	orange, black, blue		

**VPU AC II US 3+1 R 240/50**

**Weidmüller Interface GmbH & Co. KG**  
Klingenbergstraße 26  
D-32758 Detmold  
Germany

[www.weidmueller.com](http://www.weidmueller.com)

**Technical data****Ratings IECEx/ATEX/cUL**

Certificate no. (cULus) E354261

**Guarantee**

Time interval 5 years

**Important note**

Product information Only applicable to IT power systems where the earth on the distribution transformer is interconnected with the earth on the consumer side (RE=RA in Figure 44.A1 of IEC 60634-4-44:2018).

**Classifications**

ETIM 8.0	EC000941	ETIM 9.0	EC000941
ETIM 10.0	EC000941	ECLASS 14.0	27-17-12-02
ECLASS 15.0	27-17-12-02		

**Electric symbol**

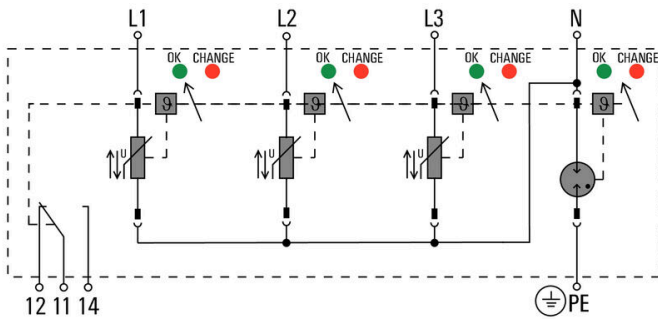

Schematic circuit diagram