

## TOP 24VDC ACT

**Weidmüller Interface GmbH & Co. KG**  
 Klingenbergstraße 26  
 D-32758 Detmold  
 Germany

www.weidmueller.com

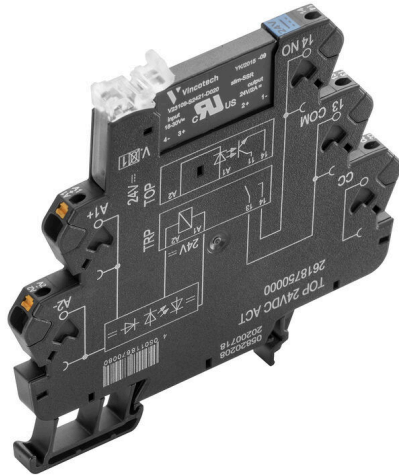

- 1 NO contact (MOS-FET)
- 6.4 mm wide
- 2 A DC output current
- Wiring optimized 24 V DC actuator version: Bridgeable, potential-free connection in the output (CC)

### General ordering data

Version	TERMSERIES, Solid-state relay, Rated control voltage: 24 V DC $\pm 20\%$ , Rated switching voltage: 3...33 V DC, Continuous current: 2 A, PUSH IN
Order No.	<a href="#">2618750000</a>
Type	TOP 24VDC ACT
GTIN (EAN)	4050118670080
Qty.	10 items

## TOP 24VDC ACT

**Weidmüller Interface GmbH & Co. KG**  
 Klingenbergstraße 26  
 D-32758 Detmold  
 Germany

www.weidmueller.com

## Technical data

### Approvals

Approvals



ROHS	Conform
UL File Number Search	<a href="#">UL Website</a>
Certificate no. (cULus)	E141197

### Dimensions and weights

Depth	87.8 mm	Depth (inches)	3.4567 inch
Height	89.4 mm	Height (inches)	3.5197 inch
Width	6.4 mm	Width (inches)	0.252 inch
Net weight	29 g		

### Temperatures

Storage temperature	-40 °C...70 °C	Ambient temperature	-20 °C...60 °C
Operating temperature		Humidity	5-95% relative humidity, Tu = 40°C, without condensation

### Probability of failure

MTTF	1077 a
------	--------

### Environmental Product Compliance

RoHS Compliance Status	Compliant with exemption
RoHS Exemption (if applicable/known)	7a, 7cl
REACH SVHC	Lead 7439-92-1
SCIP	9e2cbc49-76d9-4611-b8ec-5b4f549a0aa9

### Rated data UL

Ambient temperature (operational), max. 60 °C		Output current derating (ohmic)	1.5 A @ 60 °C, 2 A @ 55 °C
Connection cross-section AWG, min.	AWG 26	Connection cross-section AWG, max.	AWG 14
Type of conductor	rigid copper conductor, flexible copper conductor	Pollution severity level	2

### Control side

Rated control voltage	24 V DC $\pm$ 20 %	Nominal control current	11.5 mA DC ( $\pm$ 10 %)
Power rating	280 mW	Status indicator	Green LED
Protective circuit	Free-wheeling diode, Reverse polarity protection	Input frequency	300 Hz
Coil voltage of the replacement relay deviating from the rated control voltage	No	Coil voltage of the replacement relay	24 V DC

### Load side

Rated switching voltage	3...33 V DC	Continuous current	2 A
Rated switching current	2 A	Inrush current	15 A / 10 ms
Switch-on delay	$\leq$ 0,1 ms	Switch-off delay	<1 ms
Voltage drop at max. load	$\leq$ 120 mV	Leakage current	<10 $\mu$ A

## TOP 24VDC ACT

**Weidmüller Interface GmbH & Co. KG**  
 Klingenbergstraße 26  
 D-32758 Detmold  
 Germany

www.weidmueller.com

## Technical data

Min. switching current	5 mA	Short-circuit-proof	No
Protective circuit, load side	Free-wheeling diode	Contact type	1 NO contact (MOS-FET)
max. switching frequency (DC control voltage)	300 Hz		

### General data

Version	Actuator version		
Mounting rail	TS 35		
Test button available	No		
Colour	black		
UL94 flammability rating component	Component	Housing	
	UL94 flammability rating	V-0	
	Component	Retaining clip	
	UL94 flammability rating	V-0	
	Component	Pusher	
	UL94 flammability rating	V-0	

### Insulation coordination

Rated voltage	300 V	Pollution severity	2
Surge voltage category	III	Clearance and creepage distances for control side - load side	≥ 5.5 mm
Dielectric strength for control side - load side	2.5 kVeff	Dielectric strength to mounting rail	4 kVeff / 1 Min.
Impulse withstand voltage	6 kV (1.2/50 µs)	Protection degree	IP20

### Further details of approvals / standards

Certificate No. (DNV)	TAA00001E5	Certificate no. (cULus)	E141197
-----------------------	------------	-------------------------	---------

### Connection data

Wire connection method	PUSH IN	Stripping length, rated connection	9 mm
Clamping range, rated connection	1.5 mm <sup>2</sup>	Clamping range, min.	0.14 mm <sup>2</sup>
Clamping range, max.	2.5 mm <sup>2</sup>	Wire connection cross section AWG, min.	AWG 26
Wire connection cross section AWG, max.	AWG 14	Wire cross-section, solid, min.	0.14 mm <sup>2</sup>
Wire cross-section, solid, max.	1.5 mm <sup>2</sup>	Wire cross-section, solid, min. (AWG)	AWG 26
Wire cross-section, solid, max. (AWG)	AWG 16	Wire connection cross section, finely stranded, min.	0.14 mm <sup>2</sup>
Wire connection cross section, finely stranded, max.	2.5 mm <sup>2</sup>	Wire cross-section, finely stranded, min. (AWG)	AWG 26 (AWG)
Wire cross-section, finely stranded, max. (AWG)	AWG 14 (AWG)	Wire connection cross-section, finely stranded with wire-end ferrules DIN 46228/4, min.	0.14 mm <sup>2</sup>
Wire connection cross-section, finely stranded with wire-end ferrules DIN 46228/4, max.	1.5 mm <sup>2</sup>	Conductor cross-section, flexible, AEH (DIN 46228-1), min.	0.14 mm <sup>2</sup>
Conductor cross-section, flexible, AEH (DIN 46228-1), max.	1.5 mm <sup>2</sup>	Blade size	0.4 x 2.0 mm

### Classifications

ETIM 8.0	EC001504	ETIM 9.0	EC001504
ETIM 10.0	EC001504	ECLASS 14.0	27-37-16-04
ECLASS 15.0	27-37-16-04		

TOP 24VDC ACT

Weidmüller Interface GmbH & Co. KG  
Klingenbergstraße 26  
D-32758 Detmold  
Germany

Drawings

www.weidmueller.com

Wiring diagram

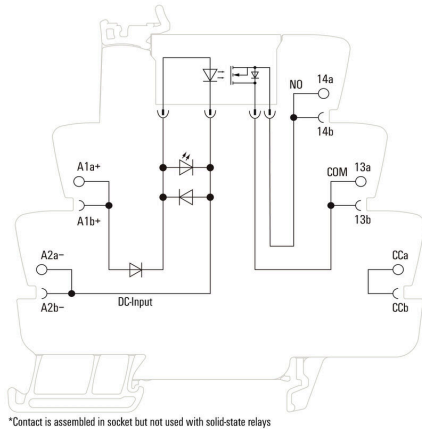

Dimensional drawing

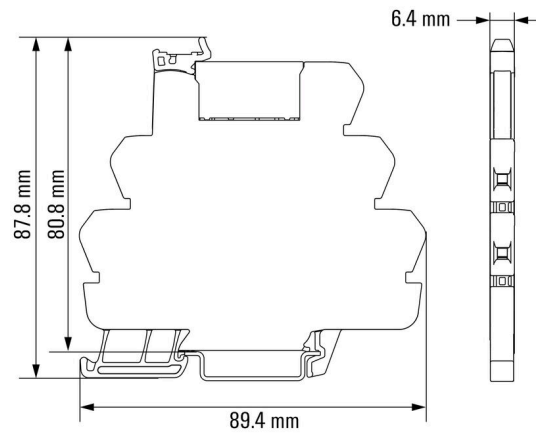

Miscellaneous

**Type code TERMSERIES solid-state relay versions**



Type codes

Drawings

**Space requirement for an 8-channel system  
 with a standard TERMSERIES 1CO relay**

Example of output wiring to show the difference in 8 loads to be wired:

Result width = 8 x 5.1 mm (2-pole terminal block) + 1 x 2.1 mm (end plate)  
 + 8 x 6.4 mm (TRP 24VDC 1CO) + 3 x 8.0 mm (end bracket) = 118.1 mm

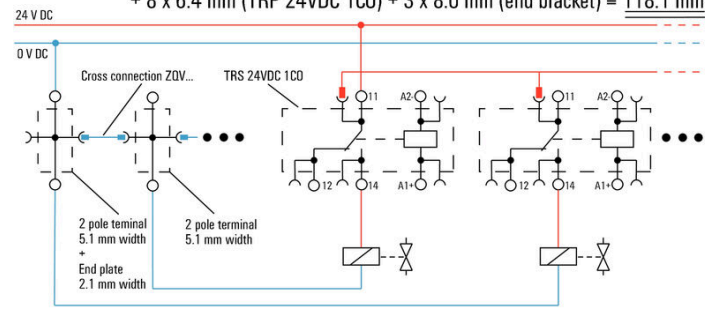

Space requirement top view:

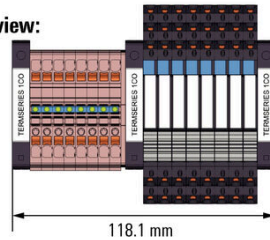

**Space requirement for an 8-channel system  
 with TERMSERIES ACT version relays and supply terminals**

Example of output wiring to show the difference in 8 loads to be wired:

Result width = 1 x 6.4 mm (TRP SUPPLY) + 8 x 6.4 mm (TRP 24VDC ACT)  
 + 2 x 8.0 mm (end bracket) = 73.6 mm

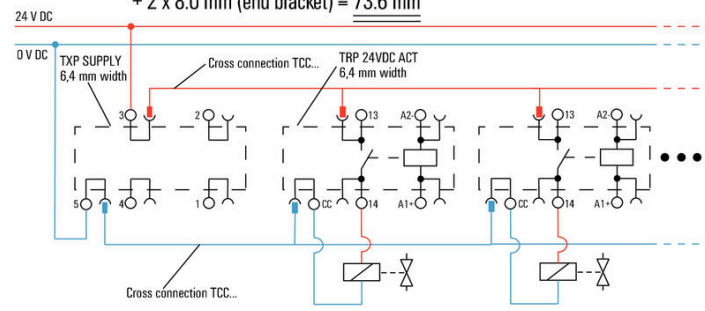

Space requirement top view:

