

TRP 120VAC RC 1CO 16A

Weidmüller Interface GmbH & Co. KG
 Klingenbergstraße 26
 D-32758 Detmold
 Germany

www.weidmueller.com

Product image



Similar to illustration



- 1 CO contact
- Contact material: AgNi
- Unique multi-voltage input from 24 to 230 V UC
- Input voltages from 5 V DC to 230 V UC with coloured marking: AC: red, DC: blue, UC: white

General ordering data

| | |
|------------|---|
| Version | TERMSERIES, Relay module, Number of contacts: 1, CO contact AgNi, Rated control voltage: 120 V AC $\pm 10\%$, Continuous current: 16 A, PUSH IN, Test button available: No |
| Order No. | 2618270000 |
| Type | TRP 120VAC RC 1CO 16A |
| GTIN (EAN) | 4050118670561 |
| Qty. | 10 items |

TRP 120VAC RC 1CO 16A

Weidmüller Interface GmbH & Co. KG

Klingenbergstraße 26

D-32758 Detmold

Germany

www.weidmueller.com

Technical data

Approvals

Approvals



ROHS Conform

UL File Number Search [UL Website](#)

Certificate no. (cULus) E141197

Dimensions and weights

| | | | |
|------------|---------|-----------------|-------------|
| Depth | 87.8 mm | Depth (inches) | 3.4567 inch |
| Height | 89.4 mm | Height (inches) | 3.5197 inch |
| Width | 12.8 mm | Width (inches) | 0.5039 inch |
| Net weight | 58 g | | |

Temperatures

| | | | |
|-----------------------|----------------|---------------------|---|
| Storage temperature | -40 °C...85 °C | Ambient temperature | -40 °C...60 °C |
| Operating temperature | | Humidity | 5-95% relative humidity, Tu = 40°C, without condensation |

Environmental Product Compliance

| | |
|--------------------------------------|--------------------------------------|
| RoHS Compliance Status | Compliant with exemption |
| RoHS Exemption (if applicable/known) | 7a, 7cl |
| REACH SVHC | Lead 7439-92-1 |
| SCIP | 9e2cbc49-76d9-4611-b8ec-5b4f549a0aa9 |

Rated data UL

| | | | |
|---|--|------------------------------------|----------------------------|
| Ambient temperature (operational), max. 60 °C | | Output current derating (ohmic) | 12 A @ 60 °C, 16 A @ 55 °C |
| Connection cross-section AWG, min. | AWG 26 | Connection cross-section AWG, max. | AWG 14 |
| Type of conductor | rigid copper conductor, flexible copper conductor | Pollution severity level | 2 |

Control side

| | | | |
|--|-----------------------|---------------------------------------|---------------|
| Rated control voltage | 120 V AC ±10 % | Rated current AC | 5.5 mA |
| Power rating | 0.6 VA | Status indicator | Green LED |
| Protective circuit | Rectifier, RC element | RC filter | 94 Ω / 100 nF |
| Coil voltage of the replacement relay deviating from the rated control voltage | Yes | Coil voltage of the replacement relay | 110 V DC |

Load side

| | | | |
|---|----------------------------|---|---------------------------|
| Rated switching voltage | 250 V AC | Continuous current | 16 A |
| Max. switching frequency at rated load | 0.1 Hz | Max. switching voltage, AC | 250 V |
| Max. switching voltage, DC | 250 V | Inrush current | 30 A / 4 s |
| AC switching capacity (resistive), max. | 4000 VA | DC switching capacity (resistive), max. | 384 W @ 24 V |
| Switch-on delay | ≤ 11 ms | Switch-off delay | ≤ 7 ms |
| Contact type | 1 CO contact (AgNi) | Mechanical service life | 30 x 106 switching cycles |
| Min. switching power | 10 mA @ 10 V, 100 mA @ 5 V | | |

TRP 120VAC RC 1CO 16A

Weidmüller Interface GmbH & Co. KG

Klingenbergstraße 26
D-32758 Detmold
Germany

www.weidmueller.com

Technical data

General data

| | | | |
|--------------------------------------|---------------------------|----------------|--|
| Operating altitude | ≤ 2000 m, above sea level | | |
| Mounting rail | TS 35 | | |
| Test button available | No | | |
| Mechanical switch position indicator | No | | |
| Colour | black | | |
| UL94 flammability rating component | Component | Housing | |
| | UL94 flammability rating | V-0 | |
| | Component | Retaining clip | |
| | UL94 flammability rating | V-0 | |
| | Component | Pusher | |
| | UL94 flammability rating | V-0 | |

Insulation coordination

| | | | |
|--|------------------|---|-----------------------|
| Rated voltage | 300 V | Pollution severity | 2 |
| Surge voltage category | III | Clearance and creepage distances for control side - load side | ≥ 6 mm |
| Dielectric strength for control side - load side | 1.2 kVeff / 5 s | Type of isolation at input and output | reinforced insulation |
| Dielectric strength of open contact | 1 kVeff / 1 min | Dielectric strength to mounting rail | 4 kVeff / 1 Min. |
| Impulse withstand voltage | 6 kV (1.2/50 µs) | Protection degree | IP20 |

Further details of approvals / standards

| | | | |
|-----------------------|------------|-------------------------|---------|
| Certificate No. (DNV) | TAA00001E5 | Certificate no. (cULus) | E141197 |
|-----------------------|------------|-------------------------|---------|

Connection data

| | | | |
|---|---------------------|---|----------------------|
| Wire connection method | PUSH IN | Stripping length, rated connection | 9 mm |
| Clamping range, rated connection | 1.5 mm ² | Clamping range, min. | 0.14 mm ² |
| Clamping range, max. | 2.5 mm ² | Wire connection cross section AWG, min. | AWG 26 |
| Wire connection cross section AWG, max. | AWG 14 | Wire cross-section, solid, min. | 0.14 mm ² |
| Wire cross-section, solid, max. | 1.5 mm ² | Wire cross-section, solid, min. (AWG) | AWG 26 |
| Wire cross-section, solid, max. (AWG) | AWG 16 | Wire connection cross section, finely stranded, min. | 0.14 mm ² |
| Wire connection cross section, finely stranded, max. | 2.5 mm ² | Wire cross-section, finely stranded, min. (AWG) | AWG 26 |
| Wire cross-section, finely stranded, max. (AWG) | AWG 14 | Wire connection cross-section, finely stranded with wire-end ferrules DIN 46228/4, min. | 0.14 mm ² |
| Wire connection cross-section, finely stranded with wire-end ferrules DIN 46228/4, max. | 1.5 mm ² | Conductor cross-section, flexible, AEH (DIN 46228-1), min. | 0.14 mm ² |
| Conductor cross-section, flexible, AEH (DIN 46228-1), max. | 1.5 mm ² | Blade size | 0.4 x 2.0 mm |

Classifications

| | | | |
|-------------|-------------|-------------|-------------|
| ETIM 8.0 | EC001437 | ETIM 9.0 | EC001437 |
| ETIM 10.0 | EC001437 | ECLASS 14.0 | 27-37-16-01 |
| ECLASS 15.0 | 27-37-16-01 | | |

TRP 120VAC RC 1CO 16A

Weidmüller Interface GmbH & Co. KG
 Klingenbergstraße 26
 D-32758 Detmold
 Germany

www.weidmueller.com

Drawings

Wiring diagram

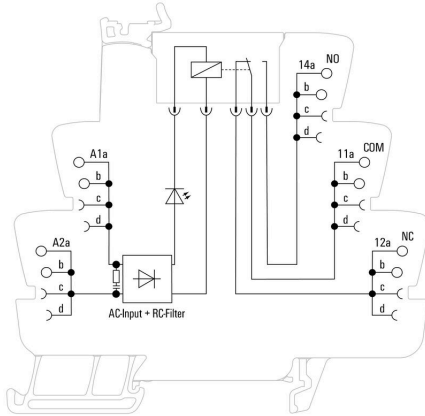

Graph



DC load limit curve Resistive load

Graph



Electrical service life 230 V AC resistive load 230 V AC resistive load

Dimensional drawing



