

**TOP 5VDC 48VDC0.1A**

**Weidmüller Interface GmbH & Co. KG**  
 Klingenbergstraße 26  
 D-32758 Detmold  
 Germany

www.weidmueller.com

**Product image**



Similar to illustration



- 1 NO contact (Bipolar transistor)
- 6.4 mm wide
- 0.1 A DC output current
- Unique multi-voltage input from 24 to 230 V UC
- Input voltages from 12 V DC to 230 V UC with coloured marking: AC: red, DC: blue, UC: white

**General ordering data**

Version	TERMSERIES, Solid-state relay, Rated control voltage: 5 V DC $\pm 20\%$ , Rated switching voltage: 3... 48 V DC, Continuous current: 0.1 A, PUSH IN
Order No.	<a href="#">2614860000</a>
Type	TOP 5VDC 48VDC0.1A
GTIN (EAN)	4050118671049
Qty.	10 items

## TOP 5VDC 48VDC0.1A

**Weidmüller Interface GmbH & Co. KG**  
 Klingenbergstraße 26  
 D-32758 Detmold  
 Germany

www.weidmueller.com

## Technical data

### Approvals

Approvals



ROHS Conform

UL File Number Search [UL Website](#)

Certificate no. (cULus) E141197

### Dimensions and weights

Depth	87.8 mm	Depth (inches)	3.4567 inch
Height	89.4 mm	Height (inches)	3.5197 inch
Width	6.4 mm	Width (inches)	0.252 inch
Net weight	29 g		

### Temperatures

Storage temperature	-40 °C...70 °C	Ambient temperature	-20 °C...60 °C
Operating temperature		Humidity	5-95% relative humidity, Tu = 40°C, without condensation

### Probability of failure

MTTF 3920 a

### Environmental Product Compliance

RoHS Compliance Status	Compliant with exemption
RoHS Exemption (if applicable/known)	7a, 7cl
REACH SVHC	Lead 7439-92-1
SCIP	9e2cbc49-76d9-4611-b8ec-5b4f549a0aa9

### Rated data UL

Ambient temperature (operational), max.	60 °C	Connection cross-section AWG, min.	AWG 26
Connection cross-section AWG, max.	AWG 14	Type of conductor	rigid copper conductor, flexible copper conductor
Pollution severity level	2		

### Control side

Rated control voltage	5 V DC $\pm$ 20 %	Nominal control current	7 mA DC ( $\pm$ 20 %)
Power rating	35 mW	Status indicator	Green LED
Protective circuit	Free-wheeling diode, Reverse polarity protection	Input frequency	10 Hz
Coil voltage of the replacement relay deviating from the rated control voltage	No	Coil voltage of the replacement relay	5 V DC

### Load side

Rated switching voltage	3... 48 V DC	Continuous current	0.1 A
Rated switching current	100 mA	Switch-on delay	<6.5 ms
Switch-off delay	<10 ms	Voltage drop at max. load	$\leq$ 1 V
Leakage current	<10 $\mu$ A	Min. switching current	500 $\mu$ A

## TOP 5VDC 48VDC0.1A

Weidmüller Interface GmbH &amp; Co. KG

Klingenbergstraße 26  
D-32758 Detmold  
Germany

www.weidmueller.com

## Technical data

Short-circuit-proof	No	Protective circuit, load side	Free-wheeling diode
Contact type	1 NO contact (Bipolar transistor)	max. switching frequency (DC control voltage)	10 Hz

## General data

Mounting rail	TS 35		
Test button available	No		
Colour	black		
UL94 flammability rating component	Component	Housing	
	UL94 flammability rating	V-0	
	Component	Retaining clip	
	UL94 flammability rating	V-0	
	Component	Pusher	
	UL94 flammability rating	V-0	

## Insulation coordination

Rated voltage	300 V	Pollution severity	2
Surge voltage category	III	Clearance and creepage distances for control side - load side	≥ 5.5 mm
Dielectric strength for control side - load side	2.5 kVeff	Dielectric strength to mounting rail	4 kVeff / 1 Min.
Impulse withstand voltage	6 kV (1.2/50 µs)	Protection degree	IP20

## Further details of approvals / standards

Certificate No. (DNV)	TAA00001E5	Certificate no. (cULus)	E141197
-----------------------	------------	-------------------------	---------

## Connection data

Wire connection method	PUSH IN	Stripping length, rated connection	9 mm
Clamping range, rated connection	1.5 mm <sup>2</sup>	Clamping range, min.	0.14 mm <sup>2</sup>
Clamping range, max.	2.5 mm <sup>2</sup>	Wire connection cross section AWG, min.	AWG 26
Wire connection cross section AWG, max.	AWG 14	Wire cross-section, solid, min.	0.14 mm <sup>2</sup>
Wire cross-section, solid, max.	1.5 mm <sup>2</sup>	Wire cross-section, solid, min. (AWG)	AWG 26
Wire cross-section, solid, max. (AWG)	AWG 16	Wire connection cross section, finely stranded, min.	0.14 mm <sup>2</sup>
Wire connection cross section, finely stranded, max.	2.5 mm <sup>2</sup>	Wire cross-section, finely stranded, min. (AWG)	AWG 26
Wire cross-section, finely stranded, max. (AWG)	AWG 14	Wire connection cross-section, finely stranded with wire-end ferrules DIN 46228/4, min.	0.14 mm <sup>2</sup>
Wire connection cross-section, finely stranded with wire-end ferrules DIN 46228/4, max.	1.5 mm <sup>2</sup>	Conductor cross-section, flexible, AEH (DIN 46228-1), min.	0.14 mm <sup>2</sup>
Conductor cross-section, flexible, AEH (DIN 46228-1), max.	1.5 mm <sup>2</sup>	Blade size	0.4 x 2.0 mm

## Classifications

ETIM 8.0	EC001504	ETIM 9.0	EC001504
ETIM 10.0	EC001504	ECLASS 14.0	27-37-16-04
ECLASS 15.0	27-37-16-04		

**Wiring diagram**

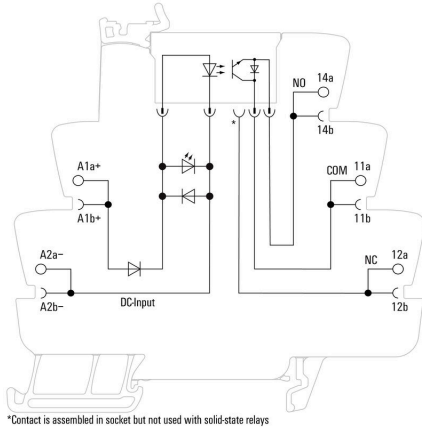

**Dimensional drawing**



Miscellaneous

Type code TERMSERIES solid-state relay versions



Type codes