

UR20-4AI-UI-DIF-32-DIAG

Weidmüller Interface GmbH & Co. KG
 Klingenbergstraße 26
 D-32758 Detmold
 Germany

www.weidmueller.com

Product image, Similar to illustration



Inputs can be parameterised; up to 3-wire + FE; accuracy 0.1% FSR

Analogue input modules of the u-remote system are available in many variants with different resolutions and wiring solutions.

Variants are available with 12- and 16-bit resolution, which record up to 4 analogue sensors with +/-10 V, +/-5 V, 0...10 V, 0...5 V, 2...10 V, 1...5 V, 0...20 mA or 4...20 mA with maximum accuracy. Each plug-in connector can optionally connect sensors with 2- or 3-wire technology. The parameters for the measurement range can be individually set for each channel. In addition, each channel has its own status LED.

A special variant for Weidmüller interface units enables current measurements with 16-bit resolution and maximum accuracy for 8 sensors at a time (0...20 mA or 4...20 mA).

The module electronics supply the connected sensors with power from the input current path (UIN).

General ordering data

Version	Remote I/O module, IP20, 4-channel, Analog signals, Input, Current/Voltage, 16 Bit
Order No.	2544660000
Type	UR20-4AI-UI-DIF-32-DIAG
GTIN (EAN)	4050118554458
Qty.	1 items

UR20-4AI-UI-DIF-32-DIAG

Weidmüller Interface GmbH & Co. KG
 Klingenbergstraße 26
 D-32758 Detmold
 Germany

www.weidmueller.com

Technical data

Approvals

Approvals



ROHS	Conform
UL File Number Search	UL Website
Certificate no. (cULus)	E141197
Certificate no. (cULusEX)	E223527

Dimensions and weights

Depth	76 mm	Depth (inches)	2.9921 inch
Height	120 mm	Height (inches)	4.7244 inch
Width	11.5 mm	Width (inches)	0.4528 inch
Net weight	90 g		

Temperatures

Storage temperature	-40 °C ... +85 °C	Operating temperature	-20 °C...60 °C
---------------------	-------------------	-----------------------	----------------

Environmental Product Compliance

RoHS Compliance Status	Compliant with exemption		
RoHS Exemption (if applicable/known)	7a, 7cl		
REACH SVHC	Lead 7439-92-1		
SCIP	82327f13-cd27-455a-ab5b-a62e1996dcf8		
Product Carbon Footprint	Cradle to gate	8,705 kg CO2 eq.	

analogue inputs

Short-circuit-proof	Yes		
Reverse polarity protection	Yes		
Accuracy	0.1% FSR		
Resolution	16 Bit		
Sensor supply	Yes		
Conversion time	1 ms		
Input type	Differential input		
Sensor supply	min.	0 A	
	nominal	0 A	
	max.	500 mA	
Module diagnosis	Yes		
Individual channel diagnosis	Yes		
Input value	Voltage U (0...5 V, ±5 V, 0...10 V, ±10 V, 1...5 V, 2...10 V), Current I (0...20 mA, 4...20 mA)		
Common mode range	min.	-30 V	
	max.	30 V	
Internal resistance U	90 kΩ		
Sensor connection	2-wire, 3-wire, 4-wire		

UR20-4AI-UI-DIF-32-DIAG

Weidmüller Interface GmbH & Co. KG

Klingenbergstraße 26

D-32758 Detmold

Germany

www.weidmueller.com

Technical data

Number analogue inputs	4
Internal resistance I	16 Ω

Connection data

Wire cross-section, finely stranded, max. (AWG)	AWG 16	Wire cross-section, finely stranded, min. (AWG)	AWG 26
Wire cross-section, solid, max. (AWG)	AWG 16	Wire cross-section, solid, min. (AWG)	AWG 26
Type of connection	PUSH IN	Wire cross-section, solid, max.	1.5 mm ²
Wire cross-section, solid, min.	0.14 mm ²	Wire connection cross section, finely stranded, max.	1.5 mm ²
Wire connection cross section, finely stranded, min.	0.14 mm ²		

General data

Vibration resistance	5 Hz ≤ f ≤ 8.4 Hz: 3.5-mm amplitude as per IEC 60068-2-6, 8.4 Hz ≤ f ≤ 150 Hz: 1 g acceleration as per IEC 60068-2-6	UL 94 flammability rating	V-0
Test voltage	500 V	Surge voltage category	II
Pollution severity	2	Mounting rail	TS 35
Air pressure (operation)	≥ 795 hPa (height ≤ 2000 m) as per DIN EN 61131-2	Air humidity (transport)	10% to 95%, non-condensing as per DIN EN 61131-2
Air pressure (transport)	1013 hPa (height 0 m) to 700 hPa (height 3000 m) as per DIN EN 61131-2	Air pressure (storage)	1013 hPa (height 0 m) to 700 hPa (height 3000 m) as per DIN EN 61131-2
Air humidity (operation)	10% to 95%, non-condensing as per DIN EN 61131-2	Air humidity (storage)	10% to 95%, non-condensing as per DIN EN 61131-2
Shock	15 g over 11 ms, half sinus wave, acc. to IEC 60068-2-27		

Power supply

Reverse polarity protection	Yes	Supply voltage	24 V DC +20 %/ -15 %, via the system bus
Current consumption from IIN (the respective power segment)	31 mA + load	Current consumption from I _{sys} , typ.	8 mA

System data

Module type	Analogue input module	Interface	u-remote system bus
Galvanic isolation	500 V DC between the current paths	Field bus protocol	PROFINET IRT, PROFINET RT, PROFIBUS DP-V1, EtherCAT, Modbus/TCP, EtherNet/IP, CANopen, DeviceNet, POWERLINK, CC-Link, CC-Link IE TSN
Transmission speed of system bus, max.	48 MBit/s	Diagnostic data	1 Bit

Classifications

ETIM 8.0	EC001596	ETIM 9.0	EC001596
ETIM 10.0	EC001596	ECLASS 14.0	27-24-26-01
ECLASS 15.0	27-24-26-01		

UR20-4AI-UI-DIF-32-DIAG

Weidmüller Interface GmbH & Co. KG
 Klingenbergstraße 26
 D-32758 Detmold
 Germany

Drawings

www.weidmueller.com

Block diagram

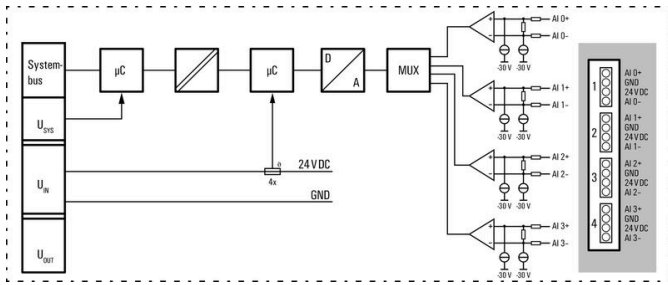

Connection diagram

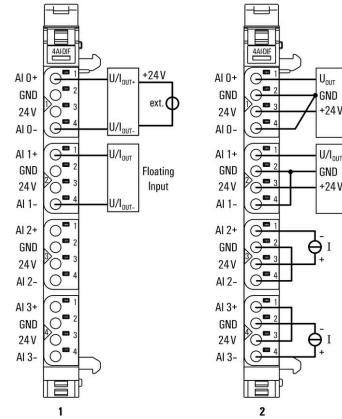

Explanation of abbreviations

Analogue input modules

