

## SAIE-M12SL-5S-F12TL-M16

**Weidmüller Interface GmbH & Co. KG**  
Klingenbergstraße 26  
D-32758 Detmold  
Germany

[www.weidmueller.com](http://www.weidmueller.com)



### General ordering data

Version	Built-in plugs, M12, Mounting thread: M 16 x 1.5, Number of poles: 5, Strand / cable length:
Order No.	<a href="#">2530880000</a>
Type	SAIE-M12SL-5S-F12TL-M16
GTIN (EAN)	4050118540994
Qty.	1 items

**SAIE-M12SL-5S-F12TL-M16**

**Weidmüller Interface GmbH & Co. KG**  
 Klingenbergstraße 26  
 D-32758 Detmold  
 Germany

www.weidmueller.com

**Technical data**

**Approvals**

ROHS Conform

**Dimensions and weights**

Net weight 25.52 g

**Environmental Product Compliance**

RoHS Compliance Status Compliant with exemption  
 RoHS Exemption (if applicable/known) 6c  
 REACH SVHC Lead 7439-92-1  
 SCIP ebf89fc8-a87f-4691-b87a-dfb9921774b4

**Technical data of PCB plug-in connector**

Number of poles	5	Coding	L-coded
Type of mounting	Frontpanel mounting	Housings	M12 pin
Installation height	12 mm	Nominal voltage	63 V
Nominal current	16 A	Protection degree	IP67, when screwed in
Contact surface	Gold over nickel	Housing main material	PA
Connection thread	M12	Tightening torque	M12: 0.8 - 1.2 Nm
Mounting thread	M 16 x 1.5	Mounting onto the PCB	Dip solder
Contact material	Cu-alloy		

**General Info**

Number of poles	5	Housing main material	PA
Connection thread	M12	Contact material	Cu-alloy
Contact surface	Gold over nickel	Type of mounting	Frontpanel mounting
Protection degree	IP67, when screwed in		

**Important note**

Notes

**Classifications**

ETIM 8.0	EC003568	ETIM 9.0	EC003568
ETIM 10.0	EC003568	ECLASS 14.0	27-44-01-10
ECLASS 15.0	27-44-01-10		

SAIE-M12SL-5S-F12TL-M16

Weidmüller Interface GmbH & Co. KG  
Klingenbergstraße 26  
D-32758 Detmold  
Germany

Drawings

www.weidmueller.com

Dimensioned drawing

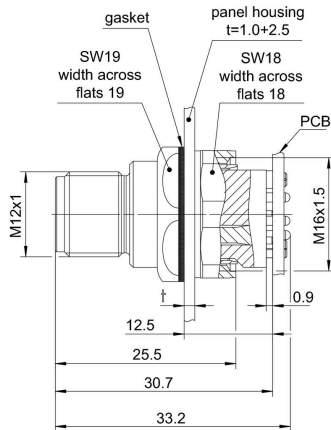

PCB design

