

UR20-1COM-CANOPEN

Weidmüller Interface GmbH & Co. KG

Klingenbergstraße 26

D-32758 Detmold

Germany

www.weidmueller.com



Digital counter and communication modules 100/500 kHz; 32-bit counter resolution; individual channel diagnosis Incremental and absolute value encoders have become indispensable in today's automated systems. Developed especially for these applications, Weidmüller offers you various counter modules that can accept an input frequency up to 500 kHz. The synchronous-serial interface (SSI) module allows high precision positioning tasks to be realised with absolute value encoders. The module can be parameterised for listening or master mode operation in order to cope with all fields of application. A module with pulse input is available to you for frequency measurement up to 100 kHz and the UR20-1CNT-500 offers an input that can accept frequencies up to 500 kHz. The UR20-2CNT-100 module has two independent counter inputs; it is supplemented with the UR20-1CNT-100-1DO module with one counter, which however offers additional options thanks to a latch, gate and reset input. This allows external control of the counter. In addition, this module can trigger an immediate event via a digital output using a set reference value. The UR20-1COM-232-485-422 module offers you extended communication options; for example devices can be integrated consistently in u-remote systems via an RS232, RS485 or RS422 interface. The UR20-1COM-SAI-PRO module presents a solution for connecting the control cabinet to the field. This gateway allows the integra-

tion of up to 15 decentral IP67 SAI-PRO Subbus modules per u-remote module.

The module electronics supply the connected sensors with power from the input current path (UIN).

The IO-Link master UR20-4COM-IO-LINK-V2 (older version: UR20-4COM-IO-LINK) supplements the u-remote platform with intelligent sensor technology. With four IO-Link channels (short-circuit-proof, with individual channel and module diagnostics) and support from the web-based u-mation configurator, it enables easy parameterisation and integration of smart field devices.

General ordering data

Version	Remote I/O module, IP20, 1-channel, CANopen, Communication module, PUSH IN connection
Order No.	2489840000
Type	UR20-1COM-CANOPEN
GTIN (EAN)	4050118499827
Qty.	1 items

UR20-1COM-CANOPEN

Weidmüller Interface GmbH & Co. KG
 Klingenbergstraße 26
 D-32758 Detmold
 Germany

www.weidmueller.com

Technical data

Approvals

Approvals



ROHS	Conform
UL File Number Search	UL Website
Certificate no. (cULus)	E141197

Dimensions and weights

Depth	76 mm	Depth (inches)	2.9921 inch
Height	120 mm	Height (inches)	4.7244 inch
Width	11.5 mm	Width (inches)	0.4528 inch
Net weight	89 g		

Temperatures

Storage temperature	-40 °C ... +85 °C	Operating temperature	-20 °C...60 °C
---------------------	-------------------	-----------------------	----------------

Environmental Product Compliance

RoHS Compliance Status	Compliant with exemption		
RoHS Exemption (if applicable/known)	7a, 7cl		
REACH SVHC	Lead 7439-92-1		
SCIP	82327f13-cd27-455a-ab5b-a62e1996dcf8		
Product Carbon Footprint	Cradle to gate		7,799 kg CO2 eq.

IO-Link interface

Number of IO-Link interfaces	0	Individual channel diagnosis of IO-Link interfaces available	No
------------------------------	---	--	----

digital inputs

Number	1	Type	1x CANopen, CANopen according to CiA DS-301 on the basis of ISO 11898, parametrisable
Module diagnosis	Yes	Individual channel diagnosis	Yes
Individual channel diagnosis	Diagnosis of the CANopen field bus		

Connection data

Wire cross-section, finely stranded, max. (AWG)	AWG 16	Wire cross-section, finely stranded, min. (AWG)	AWG 26
Wire cross-section, solid, max. (AWG)	AWG 16	Wire cross-section, solid, min. (AWG)	AWG 26
Type of connection	PUSH IN	Number	1
Wire cross-section, solid, max.	1.5 mm ²	Wire cross-section, solid, min.	0.14 mm ²
Wire connection cross section, finely stranded, max.	1.5 mm ²	Wire connection cross section, finely stranded, min.	0.14 mm ²

UR20-1COM-CANOPEN

Weidmüller Interface GmbH & Co. KG
 Klingenbergstraße 26
 D-32758 Detmold
 Germany

www.weidmueller.com

Technical data

General data

Vibration resistance	5 Hz ≤ f ≤ 8.4 Hz: 3.5-mm amplitude as per IEC 60068-2-6, 8.4 Hz ≤ f ≤ 150 Hz: 1 g acceleration as per IEC 60068-2-6	UL 94 flammability rating	V-0
Test voltage	500 V	Surge voltage category	II
Pollution severity	2	Mounting rail	TS 35
Air pressure (operation)	≥ 795 hPa (height ≤ 2000 m) as per DIN EN 61131-2	Air humidity (transport)	10% to 95%, non-condensing as per DIN EN 61131-2
Air pressure (transport)	1013 hPa (height 0 m) to 700 hPa (height 3000 m) as per DIN EN 61131-2	Air pressure (storage)	1013 hPa (height 0 m) to 700 hPa (height 3000 m) as per DIN EN 61131-2
Air humidity (operation)	10% to 95%, non-condensing as per DIN EN 61131-2	Air humidity (storage)	10% to 95%, non-condensing as per DIN EN 61131-2
Shock	15 g over 11 ms, half sinus wave, acc. to IEC 60068-2-27		

Power supply

Supply voltage	24 V DC +20 %/ -15 %, via the system bus	Current consumption from IIN (the respective power segment)	30 mA
Feed current for IIN (input current path), 30 A max.		Current consumption from Isys, typ.	8 mA

System data

Module type	Functional module	Interface	u-remote system bus
Galvanic isolation	500 V DC between the current paths	Field bus protocol	PROFINET IRT, PROFINET RT, PROFIBUS DP-V1, EtherCAT, Modbus/TCP, EtherNet/IP, CANopen, DeviceNet, POWERLINK, CC-Link, CC-Link IE TSN, IEC 61162-450
Transmission speed of system bus, max. 48 MBit/s			

Classifications

ETIM 8.0	EC001604	ETIM 9.0	EC001604
ETIM 10.0	EC001604	ECLASS 14.0	27-24-26-08
ECLASS 15.0	27-24-26-08		

UR20-1COM-CANOPEN

Weidmüller Interface GmbH & Co. KG
 Klingenbergstraße 26
 D-32758 Detmold
 Germany

www.weidmueller.com

Drawings

Block diagram

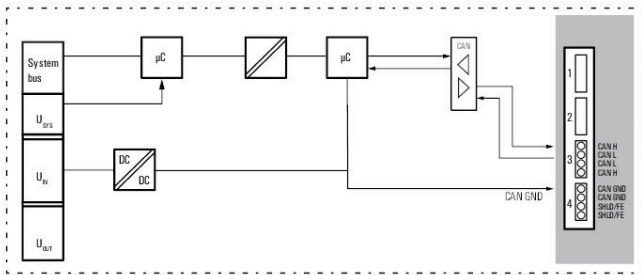

Connection diagram

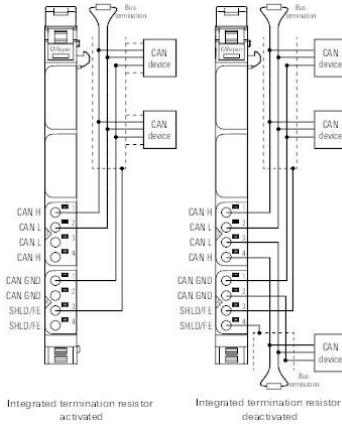

Explanation of abbreviations

Digital communication- modules

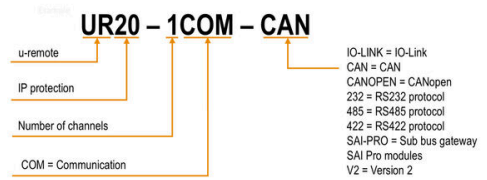

UR20-1COM-CANOPEN

Weidmüller Interface GmbH & Co. KG
 Klingenbergstraße 26
 D-32758 Detmold
 Germany

www.weidmueller.com

Accessories

Accessories



System accessory

Discover a wide range of accessories for your u-remote system - the ideal addition to make your applications even more efficient and flexible.

General ordering data

Type	UR20-EBK-ACC	Version
Order No.	1346610000	End bracket, ,
GTIN (EAN)	4050118151596	
Qty.	5 ST	

Type	UR20-SM-ACC	Version
Order No.	1339920000	Cover, ,
GTIN (EAN)	4050118144727	
Qty.	20 ST	

Blank



General ordering data

Type	PM 2.7/2.6 MC NE WS	Version
Order No.	1323710000	OMNIMATE Signal - series PM, Pusher markers, 2.7 x 2.6 mm, Pitch
GTIN (EAN)	4050118126778	in mm (P): 3.50 Weidmueller, white
Qty.	960 ST	

Custom printing



UR20-1COM-CANOPEN

Weidmüller Interface GmbH & Co. KG
 Klingenbergstraße 26
 D-32758 Detmold
 Germany

www.weidmueller.com

Accessories

General ordering data

Type	PM 2.7/2.6 MC SDR	Version	
Order No.	1323700000	OMNIMATE Signal - series PM, Pusher markers, 2.7 x 2.6 mm, Pitch in mm (P): 3.50 Weidmueller, To customer specification	
GTIN (EAN)	4050118126761		
Qty.	192 ST		
Type	DEK 5/8-11.5 MC SDR	Version	
Order No.	1341610000	Dekafix, Terminal marker, 5 x 8 mm, Pitch in mm (P): 8.00 Weidmueller, To customer specification	
GTIN (EAN)	4050118146059		
Qty.	100 ST		

Blank



The Dekafix (DEK) marker is the universal marker for all conductor and plug-in connectors as well as for electronic sub-assemblies. The system is ideal for short number sequences and covers a wide range of ready-printed markers.

Strips for fast installation in only one work step. The printing is easy to read, rich in contrast and available in various widths.

- Large range of ready-to-use markers
 - Strips for fast installation
 - Terminal markers, suitable for all Weidmüller cable connectors
 - Available as blank MultiCard or with standard printing
- For custom printing: Please send us a file of our labeling software M-Print PRO or M-Print PRO Online (without installation) for your labeling specifications.

General ordering data

Type	DEK 5/8-11.5 MC NE WS	Version	
Order No.	1341630000	Dekafix, Terminal marker, 5 x 8 mm, Pitch in mm (P): 8.00 Weidmueller, white	
GTIN (EAN)	4050118145946		
Qty.	500 ST		

Aluminum



Aluminum has the second best electrical conductivity after copper. One advantage is low weight, anMiscellaneous is outstanding corrosion protection.

General ordering data

Type	TS 35X7.5 2M/AL/BK	Version	
Order No.	0330800000	Terminal rail, Accessories, Aluminium, untreated, Width: 2000 mm, Height: 35 mm, Depth: 7.5 mm	
GTIN (EAN)	4008190100650		
Qty.	40 M		

UR20-1COM-CANOPEN

Weidmüller Interface GmbH & Co. KG
 Klingenbergstraße 26
 D-32758 Detmold
 Germany

www.weidmueller.com

Accessories

Stainless steel



Stainless steel is a collective term for all types of steel (alloys) with a high degree of purity and corrosion resistance.

General ordering data

Type	TS 35X7.5 2M/CRN	Version	
Order No.	1747350000	Terminal rail, Accessories, Stainless steel 1.4301, untreated, Width:	
GTIN (EAN)	4032248003372	2000 mm, Height: 35 mm, Depth: 7.5 mm	
Qty.	40 M		

Steel



Steel DIN rails are the most widespread on the market. Among metal DIN rails, they have the lowest shortcircuit protection, similar to stainless steel.

General ordering data

Type	TS 35X7.5 2M/ST/ZN	Version	
Order No.	0383400000	Terminal rail, Accessories, Steel, galvanic zinc plated and passivated,	
GTIN (EAN)	4008190088026	Width: 2000 mm, Height: 35 mm, Depth: 7.5 mm	
Qty.	40 M		
Type	TS 35X7.5/LL 2M/ST/ZN	Version	
Order No.	0514500000	Terminal rail, Accessories, Steel, galvanic zinc plated and passivated,	
GTIN (EAN)	4008190046019	Width: 2000 mm, Height: 35 mm, Depth: 7.5 mm	
Qty.	40 M		
Type	TS 35X7.5/LL 1M/ST/ZN	Version	
Order No.	0514510000	Terminal rail, Accessories, Steel, galvanic zinc plated and passivated,	
GTIN (EAN)	4008190116620	Width: 1000 mm, Height: 35 mm, Depth: 7.5 mm	
Qty.	20 M		
Type	TS 35X7.5/LL 2M/ST/SZ	Version	
Order No.	7915060000	Terminal rail, Accessories, Steel, galvanic zinc plated and passivated,	
GTIN (EAN)	4032248296279	Width: 2000 mm, Height: 35 mm, Depth: 7.5 mm	
Qty.	40 M		

UR20-1COM-CANOPEN

Weidmüller Interface GmbH & Co. KG
Klingenbergstraße 26
D-32758 Detmold
Germany

www.weidmueller.com

Accessories

Crimping tools



Crimping tools for wire end ferrules, with and without plastic collars

- Ratchet guarantees precise crimping
- Release option in the event of incorrect operation

General ordering data

Type	PZ 2.5 S	Version	
Order No.	2903690000		0.14mm ² , 2.5mm ² , Trapezoidal crimp
GTIN (EAN)	4099986027008		
Qty.	1 ST		