

UR20-4AI-RTD-HP-DIAG

Weidmüller Interface GmbH & Co. KG
 Klingenbergstraße 26
 D-32758 Detmold
 Germany

www.weidmueller.com

Product image, Similar to illustration



Available for TC and RTD; 16-bit resolution; 50/60 Hz suppression

The involvement of thermocouple and resistance-temperature sensors is indispensable for a variety of applications. Weidmüller's 4-channel input modules are suited for all common thermocouple elements and resistance temperature sensors. With an accuracy of 0.2% of the measurement-range end value and a resolution of 16 bit, cable break and values above or below the limit value are detected by means of individual channel diagnostics. Additional features such as an automatic 50 Hz to 60 Hz suppression or external as well as internal cold-junction compensation, as available with the RTD module, round off the scope of function.

The module electronics supply the connected sensors with power from the input current path (UIN).

General ordering data

Version	Remote I/O module, IP20, Analog signals, Temperature, RTD
Order No.	2456540000
Type	UR20-4AI-RTD-HP-DIAG
GTIN (EAN)	4050118471717
Qty.	1 items

UR20-4AI-RTD-HP-DIAG

Weidmüller Interface GmbH & Co. KG
 Klingenbergstraße 26
 D-32758 Detmold
 Germany

www.weidmueller.com

Technical data

Approvals

Approvals



ROHS	Conform
UL File Number Search	UL Website
Certificate no. (cULus)	E141197
Certificate no. (cULusEX)	E223527

Dimensions and weights

Depth	76 mm	Depth (inches)	2.9921 inch
Height	120 mm	Height (inches)	4.7244 inch
Width	11.5 mm	Width (inches)	0.4528 inch
Mounting dimension - height	128 mm	Net weight	88 g

Temperatures

Storage temperature	-40 °C ... +85 °C	Operating temperature	-20 °C...60 °C
---------------------	-------------------	-----------------------	----------------

Environmental Product Compliance

RoHS Compliance Status	Compliant with exemption		
RoHS Exemption (if applicable/known)	7a, 7cl		
REACH SVHC	Lead 7439-92-1		
SCIP	82327f13-cd27-455a-ab5b-a62e1996dcf8		
Product Carbon Footprint	Cradle to gate	8,705 kg CO2 eq.	

analogue inputs

Reverse polarity protection	Yes	Accuracy	max. 0,6 K for Measurement range Pt100 (-200 ... +250 °C), max. 0,2 % FSR for Pt sensors and resistance measurement (-200 ... +250 °C), max. 0,3 % FSR for Ni sensors, max. 0,6 % FSR for Cu10
Measured temperature value, max.	850 °C	Measured temperature value, min.	-200 °C
Type	Pt100, Pt200, Pt500, Pt1000, Ni100, Ni120, Ni 200, Ni500, Ni1000, Cu10, 40Ω, 80Ω, 150Ω, 300Ω, 500Ω, 1kΩ, 2kΩ, 4kΩ	Resolution	16 Bit
Conversion time	adjustable, 36...240 ms	Temperature coefficient	≤ 50 ppm/K
Module diagnosis	Yes	Individual channel diagnosis	Yes
Sensor connection	2-wire, 3-wire, 4-wire	Number analogue inputs	4

UR20-4AI-RTD-HP-DIAG

Weidmüller Interface GmbH & Co. KG
 Klingenbergstraße 26
 D-32758 Detmold
 Germany

www.weidmueller.com

Technical data

Connection data

Wire cross-section, finely stranded, max. (AWG)	AWG 16	Wire cross-section, finely stranded, min. (AWG)	AWG 26
Wire cross-section, solid, max. (AWG)	AWG 16	Wire cross-section, solid, min. (AWG)	AWG 26
Type of connection	PUSH IN	Wire cross-section, solid, max.	1.5 mm ²
Wire cross-section, solid, min.	0.14 mm ²	Wire connection cross section, finely stranded, max.	1.5 mm ²
Wire connection cross section, finely stranded, min.	0.14 mm ²		

General data

Vibration resistance	5 Hz ≤ f ≤ 8.4 Hz: 3.5-mm amplitude as per IEC 60068-2-6, 8.4 Hz ≤ f ≤ 150 Hz: 1 g acceleration as per IEC 60068-2-6	UL 94 flammability rating	V-0
Test voltage	500 V	Surge voltage category	II
Pollution severity	2	Mounting rail	TS 35
Air pressure (operation)	≥ 795 hPa (height ≤ 2000 m) as per DIN EN 61131-2	Air humidity (transport)	10% to 95%, non-condensing as per DIN EN 61131-2
Air pressure (transport)	1013 hPa (height 0 m) to 700 hPa (height 3000 m) as per DIN EN 61131-2	Air pressure (storage)	1013 hPa (height 0 m) to 700 hPa (height 3000 m) as per DIN EN 61131-2
Air humidity (operation)	10% to 95%, non-condensing as per DIN EN 61131-2	Air humidity (storage)	10% to 95%, non-condensing as per DIN EN 61131-2
Shock	15 g over 11 ms, half sinus wave, acc. to IEC 60068-2-27		

Power supply

Reverse polarity protection	Yes	Supply voltage	24 V DC +20 %/ -15 %, via the system bus
Current consumption from IIN (the respective power segment)	<20 mA	Current consumption from Isys, typ.	8 mA

System data

Module type	Temperature module	Interface	u-remote system bus
Galvanic isolation	500 V DC between the current paths	Field bus protocol	CANopen, DeviceNet, EtherCAT, EtherNet/IP, Modbus/TCP, PROFINET IRT, PROFIBUS DP-V1, POWERLINK
Transmission speed of system bus, max. 48 MBit/s			

Classifications

ETIM 8.0	EC001596	ETIM 9.0	EC001596
ETIM 10.0	EC001596	ECLASS 14.0	27-24-26-01
ECLASS 15.0	27-24-26-01		

UR20-4AI-RTD-HP-DIAG

Weidmüller Interface GmbH & Co. KG
 Klingenbergstraße 26
 D-32758 Detmold
 Germany

www.weidmueller.com

Drawings

Block diagram, Similar to illustration

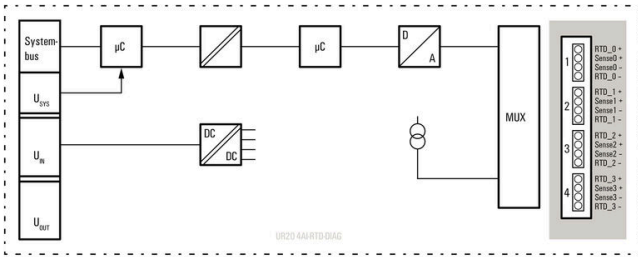

Connection diagram, Similar to illustration

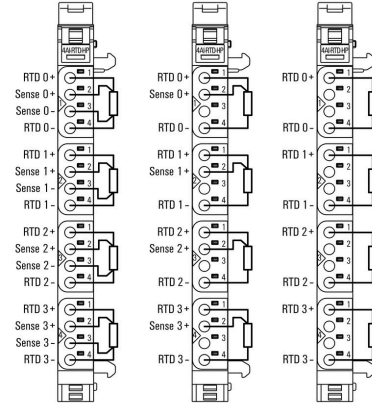

Explanation of abbreviations

Temperature modules and potentiometer input module

