

**SAIE-M8B-8S-H10THR**
**Weidmüller Interface GmbH & Co. KG**

Klingenbergstraße 26

D-32758 Detmold

Germany

www.weidmueller.com

**Similar to illustration**

Weidmüller is one of the industry's leading international providers of connectors. An important mainstay in this product family are the circular connectors, which Weidmüller groups under the product name SAI. In the development of SAI products, Weidmüller engineers have always concentrated on achieving rational, cost-effective installation concepts, and – in cooperation with major users – have supplied the markets with well-conceived products which set standards in terms of functionality and quality across the globe. The best examples are the new power distributors with S and T coded M12. These modules are characterised by particularly high currents and voltages. This enables them to also be used, for example, with three-phase motors.

**General ordering data**

Version	Built-in plugs, M8, Mounting thread: M10, Number of poles: 8, Strand / cable length:
Order No.	<a href="#">2423370000</a>
Type	SAIE-M8B-8S-H10THR
GTIN (EAN)	4050118430325
Qty.	25 items

## SAIE-M8B-8S-H10THR

Weidmüller Interface GmbH &amp; Co. KG

Klingenbergstraße 26

D-32758 Detmold

Germany

www.weidmueller.com

## Technical data

## Approvals

ROHS Conform

## Dimensions and weights

Net weight 10.08 g

## Environmental Product Compliance

RoHS Compliance Status	Compliant with exemption
RoHS Exemption (if applicable/known)	6c
REACH SVHC	Lead 7439-92-1
SCIP	0ea6d931-f9e9-40a6-89d9-8d67103189d3

## Technical data of PCB plug-in connector

Number of poles	8
Coding	M8 = none
Type of mounting	Rear panel mounting
Housings	M8 socket
Installation height	10 mm
Housing surface	nickel-plated
Shield connection	Yes
Mounting thread	Pin: M10 / Socket: M12
Nominal voltage	30 V
Rated voltage	30 V
Nominal current	1.5 A
Rated current	4 A (3-, 4- and 5-pole) / 1.5 A (8-pole)
Temperature range	-30...80 °C
Protection degree	IP67
Contact surface	Au (Gold)
Housing main material	CuZn, nickel-plated
Connection thread	M8
Tightening torque	M8: 0.5 Nm
Mounting thread	M10
Mounting torque range	0.8 Nm
Mounting torque	max. 0.8 Nm
Mounting onto the PCB	THT/THR solder connection
Insulation resistance	100 MΩ
Pollution severity	3 (2 within the sealed area)
Plugging cycles	≥ 100
Contact material	Cu-alloy
Seal material	FPM
Lock nut material	Nickel-plated CuZn
Material of the flange-mounted housing	Nickel-plated CuZn
Grouting material	PUR

## General Info

Number of poles	8	Housing main material	CuZn, nickel-plated
Connection thread	M8	Contact material	Cu-alloy
Contact surface	Au (Gold)	Type of mounting	Rear panel mounting
Protection degree	IP67	Plugging cycles	≥ 100

## SAIE-M8B-8S-H10THR

**Weidmüller Interface GmbH & Co. KG**  
 Klingenbergstraße 26  
 D-32758 Detmold  
 Germany

[www.weidmueller.com](http://www.weidmueller.com)

## Technical data

### Material data

Contact material	Cu-alloy	Contact surface	Au (Gold)
------------------	----------	-----------------	-----------

### System parameters

Mounting onto the PCB	THT/THR solder connection	Number of poles	8
Pin series quantity	1	Insulation resistance	100 MΩ
Protection degree	IP67	Plugging cycles	≥ 100

### Important note

Notes
-------

### Classifications

ETIM 8.0	EC003568	ETIM 9.0	EC003568
ETIM 10.0	EC003568	ECLASS 14.0	27-44-01-10
ECLASS 15.0	27-44-01-10		

SAIE-M8B-8S-H10THR

Weidmüller Interface GmbH & Co. KG  
 Klingenbergstraße 26  
 D-32758 Detmold  
 Germany

Drawings

www.weidmueller.com

Dimensioned drawing

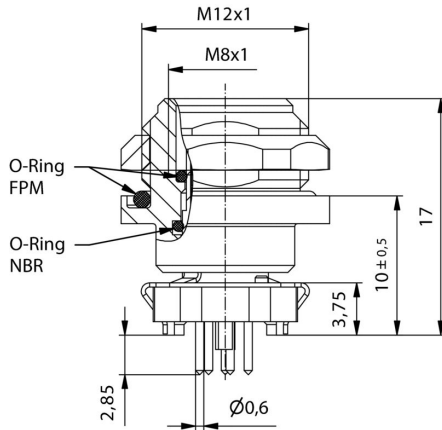

PCB design

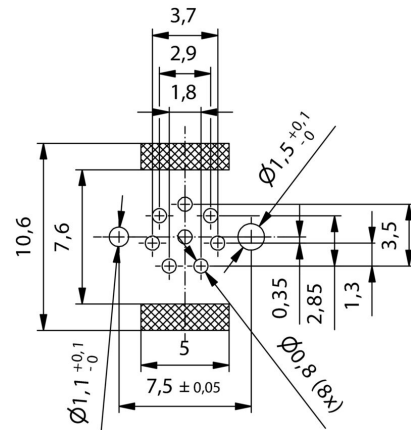

Pole scheme

