

SAIE-M8S-4S-F13THR

Weidmüller Interface GmbH & Co. KG
 Klingenbergstraße 26
 D-32758 Detmold
 Germany

www.weidmueller.com

Similar to illustration



Weidmüller is one of the industry's leading international providers of connectors. An important mainstay in this product family are the circular connectors, which Weidmüller groups under the product name SAI. In the development of SAI products, Weidmüller engineers have always concentrated on achieving rational, cost-effective installation concepts, and – in cooperation with major users – have supplied the markets with well-conceived products which set standards in terms of functionality and quality across the globe. The best examples are the new power distributors with S and T coded M12. These modules are characterised by particularly high currents and voltages. This enables them to also be used, for example, with three-phase motors.

General ordering data

Version	Built-in plugs, M8, Mounting thread: M10, Number of poles: 4, Strand / cable length:
Order No.	2423190000
Type	SAIE-M8S-4S-F13THR
GTIN (EAN)	4050118430196
Qty.	25 items

SAIE-M8S-4S-F13THR

Weidmüller Interface GmbH & Co. KG
 Klingenbergstraße 26
 D-32758 Detmold
 Germany

www.weidmueller.com

Technical data

Approvals

ROHS	Conform
------	---------

Dimensions and weights

Net weight	3.84 g
------------	--------

Environmental Product Compliance

RoHS Compliance Status	Compliant with exemption
RoHS Exemption (if applicable/known)	6c
REACH SVHC	Lead 7439-92-1
SCIP	0ea6d931-f9e9-40a6-89d9-8d67103189d3

Technical data of PCB plug-in connector

Number of poles	4
Coding	M8 = none
Type of mounting	Front mounting
Housings	M8 pin
Installation height	13 mm
Housing surface	nickel-plated
Shield connection	Yes
Mounting thread	M10
Nominal voltage	30 V
Nominal current	4 A
Temperature range	-30...80 °C
Protection degree	IP67
Contact surface	Au (Gold)
Housing main material	CuZn, nickel-plated
Connection thread	M8
Tightening torque	M8: 0.5 Nm
Mounting thread	M10
Mounting torque range	0.8 Nm
Mounting torque	max. 0.8 Nm
Mounting onto the PCB	THT/THR solder connection
Insulation resistance	100 MΩ
Pollution severity	3 (2 within the sealed area)
Plugging cycles	≥ 100
Contact material	Cu-alloy
Seal material	NBR
Lock nut material	Nickel-plated CuZn
Material of the flange-mounted housing	Nickel-plated CuZn
Grouting material	PUR

General Info

Number of poles	4	Housing main material	CuZn, nickel-plated
Connection thread	M8	Contact material	Cu-alloy
Contact surface	Au (Gold)	Type of mounting	Front mounting
Protection degree	IP67	Plugging cycles	≥ 100

Material data

Contact material	Cu-alloy	Contact surface	Au (Gold)
------------------	----------	-----------------	-----------

SAIE-M8S-4S-F13THR

Weidmüller Interface GmbH & Co. KG
 Klingenbergstraße 26
 D-32758 Detmold
 Germany

www.weidmueller.com

Technical data

System parameters

Mounting onto the PCB	THT/THR solder connection	Number of poles	4
Pin series quantity	1	Insulation resistance	100 MΩ
Protection degree	IP67	Plugging cycles	≥ 100

Important note

Notes

Classifications

ETIM 8.0	EC003568	ETIM 9.0	EC003568
ETIM 10.0	EC003568	ECLASS 14.0	27-44-01-10
ECLASS 15.0	27-44-01-10		

SAIE-M8S-4S-F13THR

Weidmüller Interface GmbH & Co. KG
 Klingenbergstraße 26
 D-32758 Detmold
 Germany

www.weidmueller.com

Drawings

Dimensioned drawing

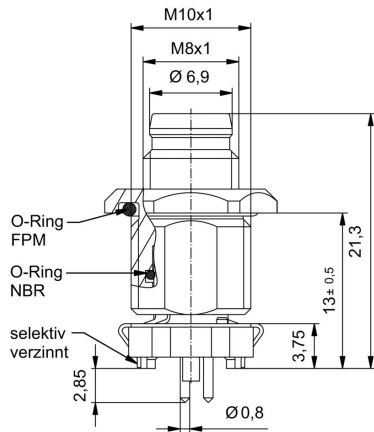

PCB design

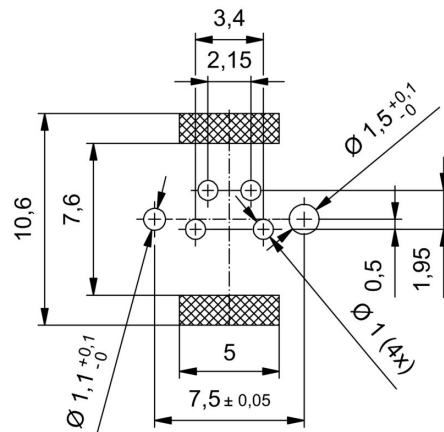

Pole scheme

