

LUP 10.16/09/90 5.0SN GY BX

Weidmüller Interface GmbH & Co. KG
 Klingenbergstraße 26
 D-32758 Detmold
 Germany

www.weidmueller.com

Product image

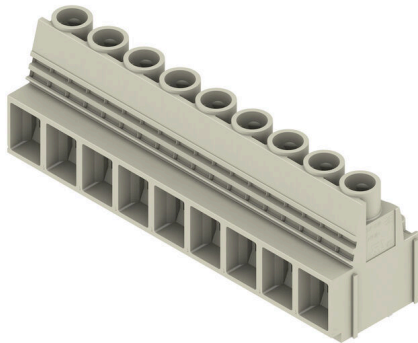

This PCB terminal provides connections for 1000 V, test point, 76 A and 16 mm² conductor cross-section with proven clamping yoke connection at 10.16 mm pitch, conductor outlet direction in 90° design.

General ordering data

| | |
|--------------|---|
| Version | Printed circuit board terminals, 10.16 mm, Number of poles: 9, 90°, Solder pin length (l): 5 mm, tinned, Pebble grey, Clamping yoke connection, Clamping range, max. : 16 mm ² , Box |
| Order No. | 2014410000 |
| Type | LUP 10.16/09/90 5.0SN GY BX |
| GTIN (EAN) | 4050118399714 |
| Qty. | 20 items |
| Product data | IEC: 1000 V / 76 A / 0.5 - 16 mm ² UL: 300 V / 58 A / AWG 26 - AWG 6 |
| Packaging | Box |

LUP 10.16/09/90 5.0SN GY BX

Weidmüller Interface GmbH & Co. KG

Klingenbergstraße 26

D-32758 Detmold

Germany

www.weidmueller.com

Technical data

Approvals

Approvals



| | |
|-------------------------|----------------------------|
| ROHS | Conform |
| UL File Number Search | UL Website |
| Certificate No. (cURus) | E60693 |

Dimensions and weights

| | | | |
|--------------------------|-------------|-----------------|-------------|
| Depth | 25.1 mm | Depth (inches) | 0.9882 inch |
| Height | 36.5 mm | Height (inches) | 1.437 inch |
| Height of lowest version | 31.5 mm | Width | 92.24 mm |
| Width (inches) | 3.6315 inch | Net weight | 83.88 g |

Environmental Product Compliance

| | |
|------------------------|-----------------------------|
| RoHS Compliance Status | Compliant without exemption |
| REACH SVHC | No SVHC above 0.1 wt% |

System parameters

| | | | |
|--|------------------------------|--|--------------------------|
| Product family | OMNIMATE Power - series LUP | Wire connection method | Clamping yoke connection |
| Mounting onto the PCB | THT solder connection | Conductor outlet direction | 90° |
| Pitch in mm (P) | 10.16 mm | Pitch in inches (P) | 0.400 " |
| Number of poles | 9 | Pin series quantity | 1 |
| Fitted by customer | Yes | Number of rows | 1 |
| Max. adjacent poles per row | 12 | Solder pin length (l) | 5 mm |
| Solder pin dimensions | 1.2 x 1.2 mm | Solder eyelet hole diameter (D) | 1.6 mm |
| Solder eyelet hole diameter tolerance (D)+ | 0,1 mm | Number of solder pins per pole | 2 |
| Screwdriver blade | 1.0 x 5.5, PZ 2 | Screwdriver blade standard | DIN 5264 |
| Tightening torque, min. | 1.2 Nm | Tightening torque, max. | 1.5 Nm |
| Clamping screw | M 4 | Stripping length | 12 mm |
| L1 in mm | 81.28 mm | L1 in inches | 3.200 " |
| Touch-safe protection acc. to DIN VDE 0470 | IP20 plugged/ IP10 unplugged | Touch-safe protection acc. to DIN VDE 57 106 | Safe from finger touch |
| Protection degree | IP20 | Volume resistance | 0.50 mΩ |

Material data

| | | | |
|---------------------------------------|------------|---------------------------------------|----------------------------------|
| Insulating material | Wemid (PA) | Colour | Pebble grey |
| Colour chart (similar) | RAL 7032 | Insulating material group | I |
| Comparative Tracking Index (CTI) | ≥ 600 | Moisture Level (MSL) | |
| UL 94 flammability rating | V-0 | Contact material | Cu-alloy |
| Contact surface | tinned | Layer structure of solder connection | 1.5...3 μm Ni / 4...6 μm Sn matt |
| Storage temperature, min. | -40 °C | Storage temperature, max. | 70 °C |
| Operating temperature, min. | -50 °C | Operating temperature, max. | 120 °C |
| Temperature range, installation, min. | -25 °C | Temperature range, installation, max. | 120 °C |

Conductors suitable for connection

| | |
|----------------------|----------------------|
| Clamping range, min. | 0.13 mm ² |
| Clamping range, max. | 16 mm ² |

LUP 10.16/09/90 5.0SN GY BX

Weidmüller Interface GmbH & Co. KG

Klingenbergstraße 26
D-32758 Detmold
Germany

www.weidmueller.com

Technical data

| | | | | |
|---|--|------------------------------|-----------------------------|-------|
| Wire connection cross section AWG, min. | AWG 22 | | | |
| Wire connection cross section AWG, max. | AWG 6 | | | |
| Solid, min. H05(07) V-U | 0.5 mm ² | | | |
| Solid, max. H05(07) V-U | 16 mm ² | | | |
| Stranded, min. H07V-R | 6 mm ² | | | |
| Stranded, max. H07V-R | 16 mm ² | | | |
| Flexible, min. H05(07) V-K | 0.5 mm ² | | | |
| Flexible, max. H05(07) V-K | 16 mm ² | | | |
| w. plastic collar ferrule, DIN 46228 pt 4, min. | 2.5 mm ² | | | |
| w. plastic collar ferrule, DIN 46228 pt 4, max. | 10 mm ² | | | |
| w. wire end ferrule, DIN 46228 pt 1, min. | 2.5 mm ² | | | |
| w. wire end ferrule, DIN 46228 pt 1, max. | 10 mm ² | | | |
| Plug gauge in accordance with EN 60999 a x b; ø | 5.4 mm x 5.1 mm; 5.3 mm | | | |
| Clampable conductor | Cross-section for conductor connection | Type | fine-wired | |
| | | nominal | 2.5 mm ² | |
| | wire end ferrule | Stripping length | nominal | 12 mm |
| | | Recommended wire-end ferrule | H2.5/12 | |
| | | Stripping length | nominal | 14 mm |
| | | Recommended wire-end ferrule | H2.5/19D BL | |
| | Cross-section for conductor connection | Type | fine-wired | |
| | | nominal | 4 mm ² | |
| | wire end ferrule | Stripping length | nominal | 12 mm |
| | | Recommended wire-end ferrule | H4.0/12 | |
| | | Stripping length | nominal | 14 mm |
| | | Recommended wire-end ferrule | H4.0/20D GR | |
| | Cross-section for conductor connection | Type | fine-wired | |
| | | nominal | 6 mm ² | |
| | wire end ferrule | Stripping length | nominal | 12 mm |
| | | Recommended wire-end ferrule | H6.0/12 | |
| | | Stripping length | nominal | 14 mm |
| | | Recommended wire-end ferrule | H6.0/20 SW | |
| | Cross-section for conductor connection | Type | fine-wired | |
| | | nominal | 10 mm ² | |
| | wire end ferrule | Stripping length | nominal | 15 mm |
| | | Recommended wire-end ferrule | H10.0/22 EB | |
| | | Stripping length | nominal | 12 mm |
| | | Recommended wire-end ferrule | H10.0/12 | |

Reference text Length of ferrules is to be chosen depending on the product and the rated voltage., The outside diameter of the plastic collar should not be larger than the pitch (P)

Rated data acc. to IEC

| | | | |
|---|------------------------|---|------|
| tested acc. to standard | IEC 60664-1, IEC 61984 | Rated current, min. number of poles (Tu=20°C) | 76 A |
| Rated current, max. number of poles (Tu=20°C) | 72 A | Rated current, min. number of poles (Tu=40°C) | 72 A |

LUP 10.16/09/90 5.0SN GY BX

Weidmüller Interface GmbH & Co. KG
 Klingenbergstraße 26
 D-32758 Detmold
 Germany

www.weidmueller.com

Technical data

| | | | |
|---|--------|---|-------------------|
| Rated current, max. number of poles (Tu=40°C) | 62 A | Rated voltage for surge voltage class / pollution degree II/2 | 1000 V |
| Rated voltage for surge voltage class / pollution degree III/2 | 1000 V | Rated voltage for surge voltage class / pollution degree III/3 | 800 V |
| Rated impulse voltage for surge voltage class/ pollution degree II/2 | 6 kV | Rated impulse voltage for surge voltage class/ pollution degree III/2 | 8 kV |
| Rated impulse voltage for surge voltage class/ contamination degree III/3 | 8 kV | Short-time withstand current resistance | 1 x 1s with 700 A |

Rated data acc. to CSA

| | | | |
|-----------------------------------|--|-----------------------------------|----------------|
| Institute (CSA) | CSA | Certificate No. (CSA) | 200039-1198743 |
| Rated voltage (Use group B / CSA) | 300 V | Rated voltage (Use group C / CSA) | 300 V |
| Rated voltage (Use group D / CSA) | 600 V | Rated current (Use group B / CSA) | 58 A |
| Rated current (Use group C / CSA) | 58 A | Rated current (Use group D / CSA) | 5 A |
| Wire cross-section, AWG, min. | AWG 22 | Wire cross-section, AWG, max. | AWG 6 |
| Reference to approval values | Specifications are maximum values, details - see approval certificate. | | |

Rated data acc. to UL 1059

| | | | |
|---------------------------------------|--|---------------------------------------|--------|
| Institute (cURus) | CURUS | Certificate No. (cURus) | E60693 |
| Rated voltage (Use group B / UL 1059) | 300 V | Rated voltage (Use group C / UL 1059) | 300 V |
| Rated voltage (Use group D / UL 1059) | 600 V | Rated current (Use group B / UL 1059) | 58 A |
| Rated current (Use group C / UL 1059) | 58 A | Rated current (Use group D / UL 1059) | 5 A |
| Wire cross-section, AWG, min. | AWG 26 | Wire cross-section, AWG, max. | AWG 6 |
| Reference to approval values | Specifications are maximum values, details - see approval certificate. | | |

Packing

| | | | |
|-----------|-----------|------------|-----------|
| Packaging | Box | VPE length | 208.00 mm |
| VPE width | 174.00 mm | VPE height | 60.00 mm |

Type tests

| | | | |
|---|----------------|--|------------------------------|
| Test: Durability of markings | Standard | DIN EN 61984 section 7.3.2 / 09.02 taking pattern from DIN EN 60068-2-70 / 07.96 | |
| | Test | mark of origin, type identification, type of material, approval marking UL, durability | |
| | Evaluation | available | |
| | Standard | DIN EN 61984 section 7.3.2 / 09.02 taking pattern from DIN EN 60068-2-70 / 07.96 | |
| Test: Clampable cross section | Test | approval marking CSA, approval marking SEV | |
| | Standard | DIN EN 60999-1 section 7 and 9.1 / 12.00, DIN EN 60947-1 section 8.2.4.5.1 / 12.02 | |
| | Conductor type | Type of conductor and conductor cross-section | solid 0.5 mm ² |
| | | Type of conductor and conductor cross-section | stranded 0.5 mm ² |
| | | Type of conductor and conductor cross-section | solid 16 mm ² |
| Type of conductor and conductor cross-section | | stranded 16 mm ² | |

LUP 10.16/09/90 5.0SN GY BX

Weidmüller Interface GmbH & Co. KG
 Klingenbergstraße 26
 D-32758 Detmold
 Germany

www.weidmueller.com

Technical data

| | | |
|------------|---|----------|
| | Type of conductor and conductor cross-section | H07V-U16 |
| | Type of conductor and conductor cross-section | AWG 6/7 |
| Evaluation | passed | |

Important note

| | |
|----------------|--|
| IPC conformity | Conformity: The products are developed, manufactured and delivered according international recognized standards and norms and comply with the assured properties in the data sheet resp. fulfill decorative properties in accordance with IPC-A-6 10 "Class 2". Further claims on the products can be evaluated on request. |
| Notes | <ul style="list-style-type: none"> • Additional variants on request • Rated current related to rated cross-section & min. No. of poles. • Wire end ferrule without plastic collar to DIN 46228/1 • Wire end ferrule with plastic collar to DIN 46228/4 • The data given under CSA relates to a cUL approval - E60693 • P on drawing = pitch • Rated data refer only to the component itself. Clearance and creepage distances to other components are to be designed in accordance with the relevant application standards. • The test point can only be used as potential-pickup point. • Long term storage of the product with average temperature of 50 °C and maximum humidity 70%, 36 months |

Classifications

| | | | |
|-------------|-------------|-------------|-------------|
| ETIM 8.0 | EC002643 | ETIM 9.0 | EC002643 |
| ETIM 10.0 | EC002643 | ECLASS 14.0 | 27-46-01-01 |
| ECLASS 15.0 | 27-46-01-01 | | |

LUP 10.16/09/90 5.0SN GY BX

Weidmüller Interface GmbH & Co. KG
 Klingenbergstraße 26
 D-32758 Detmold
 Germany

www.weidmueller.com

Drawings

Product image

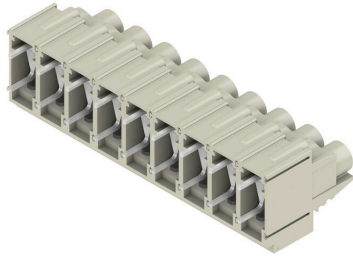

Dimensional drawing

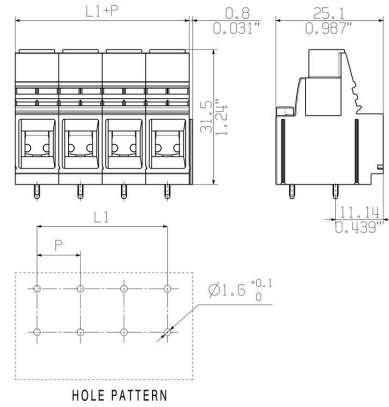

Graph

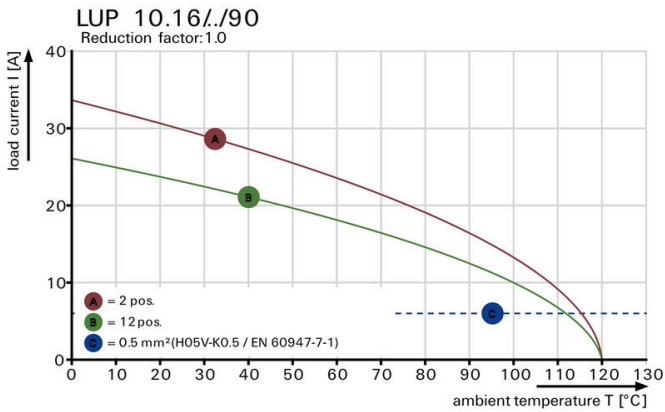

Graph

