

## LP 7.62/02/180 3.2SN OR BX

**Weidmüller Interface GmbH & Co. KG**  
 Klingenbergstraße 26  
 D-32758 Detmold  
 Germany

www.weidmueller.com

### Product image

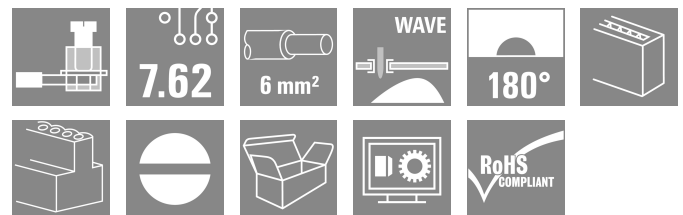

Similar to illustration

This PCB terminal provides connections for 1000 V, 6 mm<sup>2</sup> conductor cross-section and 32 A with proven clamping yoke connection at 7.50 mm and 7.62 mm pitch, conductor outlet direction in 90° and 180° design.

### General ordering data

|              |   |
|--------------|---|
| Version      | Printed circuit board terminals, 7.62 mm, Number of poles: 2, 180°, Solder pin length (l): 3.2 mm, tinned, orange, Clamping yoke connection, Clamping range, max. : 6 mm <sup>2</sup> , Box |
| Order No.    | <a href="#">1753890000</a>  |
| Type         | LP 7.62/02/180 3.2SN OR BX  |
| GTIN (EAN)   | 403224806527 1  |
| Qty.         | 100 items   |
| Product data | IEC: 1000 V / 32 A / 0.5 - 6 mm <sup>2</sup><br>UL: 300 V / 20 A / AWG 26 - AWG 12  |
| Packaging    | Box   |

## LP 7.62/02/180 3.2SN OR BX

Weidmüller Interface GmbH &amp; Co. KG

Klingenbergstraße 26

D-32758 Detmold

Germany

www.weidmueller.com

## Technical data

## Approvals

Approvals



ROHS Conform

UL File Number Search [UL Website](#)

Certificate No. (UR) E60693

## Dimensions and weights

|                          |             |                 |             |
|--------------------------|-------------|-----------------|-------------|
| Depth                    | 19 mm       | Depth (inches)  | 0.748 inch  |
| Height                   | 14.2 mm     | Height (inches) | 0.5591 inch |
| Height of lowest version | 11 mm       | Width           | 15.84 mm    |
| Width (inches)           | 0.6236 inch | Net weight      | 3.05 g      |

## Environmental Product Compliance

RoHS Compliance Status Compliant without exemption

REACH SVHC No SVHC above 0.1 wt%

## System parameters

|  |                             |  |                          |
|--|-----------------------------|--|--------------------------|
| Product family                             | OMNIMATE Signal - series LP | Wire connection method                       | Clamping yoke connection |
| Mounting onto the PCB                      | THT solder connection       | Conductor outlet direction                   | 180°                     |
| Pitch in mm (P)                            | 7.62 mm                     | Pitch in inches (P)                          | 0.300 "                  |
| Number of poles                            | 2                           | Pin series quantity                          | 1                        |
| Fitted by customer                         | Yes                         | Number of rows                               | 1                        |
| Max. adjacent poles per row                | 16                          | Solder pin length (l)                        | 3.2 mm                   |
| Solder pin dimensions                      | 0.75 x 0.9 mm               | Solder eyelet hole diameter (D)              | 1.3 mm                   |
| Solder eyelet hole diameter tolerance (D)+ | 0,1 mm                      | Number of solder pins per pole               | 1                        |
| Screwdriver blade                          | 0.6 x 3.5                   | Screwdriver blade standard                   | DIN 5264                 |
| Tightening torque, min.                    | 0.5 Nm                      | Tightening torque, max.                      | 0.6 Nm                   |
| Clamping screw                             | M 3                         | Stripping length                             | 6 mm                     |
| L1 in mm                                   | 7.62 mm                     | L1 in inches                                 | 0.300 "                  |
| Touch-safe protection acc. to DIN VDE 0470 | IP 20                       | Touch-safe protection acc. to DIN VDE 57 106 | Safe from finger touch   |
| Protection degree                          | IP20                        | Volume resistance                            | 1.20 mΩ                  |

## Material data

|                                       |          |                                       |                           |
|---------------------------------------|----------|---------------------------------------|---------------------------|
| Insulating material                   | PA       | Colour                                | orange                    |
| Colour chart (similar)                | RAL 2000 | Insulating material group             | I                         |
| Comparative Tracking Index (CTI)      | ≥ 600    | Moisture Level (MSL)                  |                           |
| UL 94 flammability rating             | V-2      | Contact material                      | Cu-alloy                  |
| Contact surface                       | tinned   | Coating                               | 1-3 μm Ni, 4-6 μm SN      |
| Tinning type                          | matt     | Layer structure of solder connection  | 4...6 μm Ni / 4...6 μm Sn |
| Storage temperature, min.             | -40 °C   | Storage temperature, max.             | 70 °C                     |
| Operating temperature, min.           | -50 °C   | Operating temperature, max.           | 100 °C                    |
| Temperature range, installation, min. | -25 °C   | Temperature range, installation, max. | 100 °C                    |

## Conductors suitable for connection

|                      |                      |
|----------------------|----------------------|
| Clamping range, min. | 0.13 mm <sup>2</sup> |
| Clamping range, max. | 6 mm <sup>2</sup>    |

## LP 7.62/02/180 3.2SN OR BX

**Weidmüller Interface GmbH & Co. KG**  
 Klingenbergstraße 26  
 D-32758 Detmold  
 Germany

www.weidmueller.com

## Technical data

|   |  |                              |                            |      |
|---|--|------------------------------|----------------------------|------|
| Wire connection cross section AWG, min.         | AWG 26   |                              |                            |      |
| Wire connection cross section AWG, max.         | AWG 12   |                              |                            |      |
| Solid, min. H05(07) V-U                         | 0.5 mm <sup>2</sup>  |                              |                            |      |
| Solid, max. H05(07) V-U                         | 6 mm <sup>2</sup>  |                              |                            |      |
| Stranded, max. H07V-R                           | 6 mm <sup>2</sup>  |                              |                            |      |
| Flexible, min. H05(07) V-K                      | 0.5 mm <sup>2</sup>  |                              |                            |      |
| Flexible, max. H05(07) V-K                      | 4 mm <sup>2</sup>  |                              |                            |      |
| w. plastic collar ferrule, DIN 46228 pt 4, min. | 0.5 mm <sup>2</sup>  |                              |                            |      |
| w. plastic collar ferrule, DIN 46228 pt 4, max. | 2.5 mm <sup>2</sup>  |                              |                            |      |
| w. wire end ferrule, DIN 46228 pt 1, min.       | 0.5 mm <sup>2</sup>  |                              |                            |      |
| w. wire end ferrule, DIN 46228 pt 1, max.       | 2.5 mm <sup>2</sup>  |                              |                            |      |
| Plug gauge in accordance with EN 60999 a x b; ø | 2.8 mm x 2.4 mm; 3.0 mm  |                              |                            |      |
| Clampable conductor                             | Cross-section for conductor connection   | Type                         | fine-wired                 |      |
|   |  | nominal                      | 0.5 mm <sup>2</sup>        |      |
|   | wire end ferrule   | Stripping length             | nominal                    | 8 mm |
|   |  | Recommended wire-end ferrule | <a href="#">H0.5/12 OR</a> |      |
|   |  | Stripping length             | nominal                    | 6 mm |
|   |  | Recommended wire-end ferrule | <a href="#">H0.5/6</a>     |      |
|   | Cross-section for conductor connection   | Type                         | fine-wired                 |      |
|   |  | nominal                      | 0.75 mm <sup>2</sup>       |      |
|   | wire end ferrule   | Stripping length             | nominal                    | 8 mm |
|   |  | Recommended wire-end ferrule | <a href="#">H0.75/12 W</a> |      |
|   |  | Stripping length             | nominal                    | 6 mm |
|   |  | Recommended wire-end ferrule | <a href="#">H0.75/6</a>    |      |
| Cross-section for conductor connection          | Type   | fine-wired                   |                            |      |
|   | nominal  | 1 mm <sup>2</sup>            |                            |      |
| wire end ferrule                                | Stripping length   | nominal                      | 8 mm                       |      |
|   | Recommended wire-end ferrule   | <a href="#">H1.0/12 GE</a>   |                            |      |
|   | Stripping length   | nominal                      | 6 mm                       |      |
|   | Recommended wire-end ferrule   | <a href="#">H1.0/6</a>       |                            |      |
| Reference text                                  | Length of ferrules is to be chosen depending on the product and the rated voltage.. The outside diameter of the plastic collar should not be larger than the pitch (P) |                              |                            |      |

### Rated data acc. to IEC

|   |                        |   |                   |
|---|------------------------|---|-------------------|
| tested acc. to standard   | IEC 60664-1, IEC 61984 | Rated current, min. number of poles (Tu=20°C)                         | 32 A              |
| Rated current, max. number of poles (Tu=20°C)                             | 32 A                   | Rated current, min. number of poles (Tu=40°C)                         | 32 A              |
| Rated current, max. number of poles (Tu=40°C)                             | 30.5 A                 | Rated voltage for surge voltage class / pollution degree II/2         | 1000 V            |
| Rated voltage for surge voltage class / pollution degree III/2            | 500 V                  | Rated voltage for surge voltage class / pollution degree III/3        | 500 V             |
| Rated impulse voltage for surge voltage class/ pollution degree II/2      | 6 kV                   | Rated impulse voltage for surge voltage class/ pollution degree III/2 | 6 kV              |
| Rated impulse voltage for surge voltage class/ contamination degree III/3 | 6 kV                   | Short-time withstand current resistance                               | 3 x 1s with 120 A |

**LP 7.62/02/180 3.2SN OR BX**

**Weidmüller Interface GmbH & Co. KG**  
 Klingenbergstraße 26  
 D-32758 Detmold  
 Germany

www.weidmueller.com

**Technical data**

**Rated data acc. to CSA**

|                                   |  |                                   |                |
|-----------------------------------|--|-----------------------------------|----------------|
| Institute (CSA)                   | CSA  | Certificate No. (CSA)             | 200039-1202191 |
| Rated voltage (Use group B / CSA) | 300 V  | Rated voltage (Use group D / CSA) | 300 V          |
| Rated current (Use group B / CSA) | 20 A   | Rated current (Use group D / CSA) | 10 A           |
| Wire cross-section, AWG, min.     | AWG 26   | Wire cross-section, AWG, max.     | AWG 12         |
| Reference to approval values      | Specifications are maximum values, details - see approval certificate. |                                   |                |

**Rated data acc. to UL 1059**

|                                       |  |                                       |        |
|---------------------------------------|--|---------------------------------------|--------|
| Institute (UR)                        | UR   | Certificate No. (UR)                  | E60693 |
| Rated voltage (Use group B / UL 1059) | 300 V  | Rated voltage (Use group D / UL 1059) | 300 V  |
| Rated current (Use group B / UL 1059) | 20 A   | Rated current (Use group D / UL 1059) | 10 A   |
| Wire cross-section, AWG, min.         | AWG 26   | Wire cross-section, AWG, max.         | AWG 12 |
| Reference to approval values          | Specifications are maximum values, details - see approval certificate. |                                       |        |

**Packing**

|           |          |            |           |
|-----------|----------|------------|-----------|
| Packaging | Box      | VPE length | 101.00 mm |
| VPE width | 87.00 mm | VPE height | 82.00 mm  |

**Type tests**

|   |                |  |                               |
|---|----------------|--|-------------------------------|
| Test: Durability of markings                              | Standard       | draft DIN VDE 0627 section 6.2.2 / 09.91   |                               |
|   | Test           | mark of origin, type identification, rated voltage, rated cross-section, pitch, approval marking SEV, durability |                               |
|   | Evaluation     | available  |                               |
| Test: Clampable cross section                             | Standard       | DIN EN 60999 section 6 and 8.1 / 04.94, DIN EN 60947-1 section 8.2.4.5.1 / 07.98                                 |                               |
|   | Conductor type | Type of conductor and conductor cross-section  | solid 0,12 mm <sup>2</sup>    |
|   |                | Type of conductor and conductor cross-section  | flexible 0,12 mm <sup>2</sup> |
|   |                | Type of conductor and conductor cross-section  | flexible 4 mm <sup>2</sup>    |
|   |                | Type of conductor and conductor cross-section  | solid 6 mm <sup>2</sup>       |
|   |                | Type of conductor and conductor cross-section  | AWG 26/1                      |
|   |                | Type of conductor and conductor cross-section  | AWG 26/19                     |
|   |                | Type of conductor and conductor cross-section  | AWG 12/1                      |
|   |                | Type of conductor and conductor cross-section  | AWG 12/19                     |
| Evaluation  | passed         |  |                               |
| Test for damage to and accidental loosening of conductors | Standard       | DIN EN 60999 section 8.4 / 04.94   |                               |
|   | Requirement    | 0.2 kg   |                               |

**LP 7.62/02/180 3.2SN OR BX**

**Weidmüller Interface GmbH & Co. KG**  
 Klingenbergstraße 26  
 D-32758 Detmold  
 Germany

www.weidmueller.com

**Technical data**

|                |   |   |                              |
|----------------|---|---|------------------------------|
| Pull-out test  | Conductor type                                | Type of conductor and conductor cross-section | AWG 26/1                     |
|                |   | Type of conductor and conductor cross-section | AWG 26/19                    |
|                | Evaluation                                    | passed  |                              |
|                | Requirement                                   | 0.3 kg  |                              |
|                | Conductor type                                | Type of conductor and conductor cross-section | solid 0.5 mm <sup>2</sup>    |
|                |   | Type of conductor and conductor cross-section | stranded 0.5 mm <sup>2</sup> |
|                | Evaluation                                    | passed  |                              |
|                | Requirement                                   | 0.9 kg  |                              |
|                | Conductor type                                | Type of conductor and conductor cross-section | flexible 4 mm <sup>2</sup>   |
|                |   | Type of conductor and conductor cross-section | AWG 12/1                     |
|                |   | Type of conductor and conductor cross-section | AWG 12/19                    |
|                | Evaluation                                    | passed  |                              |
|                | Requirement                                   | 1.4 kg  |                              |
|                | Conductor type                                | Type of conductor and conductor cross-section | solid 6 mm <sup>2</sup>      |
|                | Evaluation                                    | passed  |                              |
| Standard       | DIN EN 60999 section 8.5 / 04.94              |   |                              |
| Requirement    | ≥10 N   |   |                              |
| Conductor type | Type of conductor and conductor cross-section | AWG 26/1                                      |                              |
|                | Type of conductor and conductor cross-section | AWG 26/19                                     |                              |
| Evaluation     | passed  |   |                              |
| Requirement    | ≥30 N   |   |                              |
| Conductor type | Type of conductor and conductor cross-section | H05V-U0.5                                     |                              |
|                | Type of conductor and conductor cross-section | H05V-K0.5                                     |                              |
| Evaluation     | passed  |   |                              |
| Requirement    | ≥60 N   |   |                              |
| Conductor type | Type of conductor and conductor cross-section | H07V-K4                                       |                              |
|                | Type of conductor and conductor cross-section | AWG 12/1                                      |                              |
|                | Type of conductor and conductor cross-section | AWG 12/19                                     |                              |
| Evaluation     | passed  |   |                              |
| Requirement    | ≥80 N   |   |                              |
| Conductor type | Type of conductor and conductor cross-section | H07V-U6                                       |                              |

Technical data

Evaluation | passed

**Important note**

IPC conformity      Conformity: The products are developed, manufactured and delivered according international recognized standards and norms and comply with the assured properties in the data sheet resp. fulfill decorative properties in accordance with IPC-A-610 "Class 2". Further claims on the products can be evaluated on request.

- Notes
- Additional variants on request
  - Rated current related to rated cross-section & min. No. of poles.
  - Wire end ferrule without plastic collar to DIN 46228/1
  - Wire end ferrule with plastic collar to DIN 46228/4
  - P on drawing = pitch
  - Rated data refer only to the component itself. Clearance and creepage distances to other components are to be designed in accordance with the relevant application standards.
  - It is necessary to hold the insulating body of the one or two pole terminal when tightening the screw
  - Long term storage of the product with average temperature of 50 °C and maximum humidity 70%, 36 months

**Classifications**

|             |             |             |             |
|-------------|-------------|-------------|-------------|
| ETIM 8.0    | EC002643    | ETIM 9.0    | EC002643    |
| ETIM 10.0   | EC002643    | ECLASS 14.0 | 27-46-01-01 |
| ECLASS 15.0 | 27-46-01-01 |             |             |

Drawings

Dimensional drawing

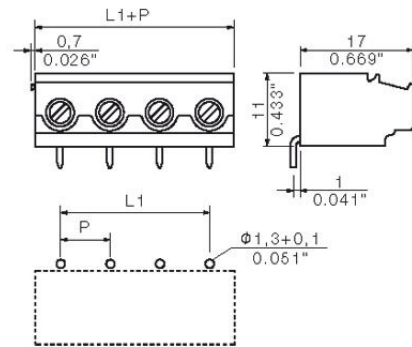

Graph

