

TOS 24VDC ACT

Weidmüller Interface GmbH & Co. KG
 Klingenbergstraße 26
 D-32758 Detmold
 Germany

www.weidmueller.com

Product image



Similar to illustration

General ordering data

Version	TERMSERIES, Solid-state relay, Rated control voltage: 24 V DC $\pm 20\%$, Rated switching voltage: 3...33 V DC, Continuous current: 2 A, Screw connection
Order No.	1391680000
Type	TOS 24VDC ACT
GTIN (EAN)	4050118192070
Qty.	10 items

TOS 24VDC ACT

Weidmüller Interface GmbH & Co. KG

Klingenbergstraße 26

D-32758 Detmold

Germany

www.weidmueller.com

Technical data

Approvals

Approvals



ROHS Conform

UL File Number Search [UL Website](#)

Certificate no. (cULus) E141197

Dimensions and weights

Depth	87.8 mm	Depth (inches)	3.4567 inch
Height	89.6 mm	Height (inches)	3.5276 inch
Width	6.4 mm	Width (inches)	0.252 inch
Net weight	31.4 g		

Temperatures

Storage temperature	-40 °C...70 °C	Ambient temperature	-20 °C...60 °C
Operating temperature		Humidity	5-95% relative humidity, Tu = 40°C, without condensation

Probability of failure

MTTF 1077 a

Environmental Product Compliance

RoHS Compliance Status	Compliant with exemption
RoHS Exemption (if applicable/known)	7a, 7cl
REACH SVHC	Lead 7439-92-1
SCIP	9e2cbc49-76d9-4611-b8ec-5b4f549a0aa9

Rated data UL

Ambient temperature (operational), max. 60 °C		Output current derating (ohmic)	1.5 A @ 60 °C, 2 A @ 55 °C
Connection cross-section AWG, min.	AWG 26	Connection cross-section AWG, max.	AWG 14
Type of conductor	rigid copper conductor, flexible copper conductor	Tightening torque, max.	0.4 Nm
Pollution severity level	2		

Control side

Rated control voltage	24 V DC \pm 20 %	Nominal control current	11.5 mA DC (\pm 10 %)
Power rating	280 mW	Status indicator	Green LED
Protective circuit	Free-wheeling diode, Reverse polarity protection	Input frequency	300 Hz
Coil voltage of the replacement relay deviating from the rated control voltage	No	Coil voltage of the replacement relay	24 V DC

Load side

Rated switching voltage	3...33 V DC	Continuous current	2 A
Rated switching current	2 A	Inrush current	15 A / 10 ms

TOS 24VDC ACT

Weidmüller Interface GmbH & Co. KG

Klingenbergstraße 26
D-32758 Detmold
Germany

www.weidmueller.com

Technical data

Switch-on delay	≤0,1 ms	Switch-off delay	<1 ms
Voltage drop at max. load	≤ 120 mV	Leakage current	<10 µA
Min. switching current	5 mA	Short-circuit-proof	No
Protective circuit, load side	Free-wheeling diode	Contact type	1 NO contact (MOS-FET)
max. switching frequency (DC control voltage)	300 Hz		

General data

Version	Actuator version		
Mounting rail	TS 35		
Test button available	No		
Colour	black		
UL94 flammability rating component	Component	Housing	
	UL94 flammability rating	V-0	
	Component	Retaining clip	
	UL94 flammability rating	V-0	

Insulation coordination

Rated voltage	300 V	Pollution severity	2
Surge voltage category	III	Clearance and creepage distances for control side - load side	≥ 5.5 mm
Dielectric strength for control side - load side	2.5 kVeff	Dielectric strength to mounting rail	4 kVeff / 1 Min.
Impulse withstand voltage	6 kV (1.2/50 µs)	Protection degree	IP20

Further details of approvals / standards

Certificate No. (DNV)	TAA00001E5	Certificate no. (cULus)	E141197
-----------------------	------------	-------------------------	---------

Connection data

Wire connection method	Screw connection	Stripping length, rated connection	8 mm
Tightening torque, max.	0.4 Nm	Clamping range, rated connection	1.5 mm ²
Clamping range, min.	0.14 mm ²	Clamping range, max.	2.5 mm ²
Wire connection cross section AWG, min.	AWG 26	Wire connection cross section AWG, max.	AWG 14
Wire cross-section, solid, min.	0.14 mm ²	Wire cross-section, solid, max.	2.5 mm ²
Wire cross-section, solid, min. (AWG)	AWG 26	Wire cross-section, solid, max. (AWG)	AWG 14
Wire connection cross section, finely stranded, min.	0.14 mm ²	Wire connection cross section, finely stranded, max.	2.5 mm ²
Wire cross-section, finely stranded, min. (AWG)	AWG 26	Wire cross-section, finely stranded, max. (AWG)	AWG 14
Wire connection cross-section, finely stranded with wire-end ferrules DIN 46228/4, min.	0.25 mm ²	Wire connection cross-section, finely stranded with wire-end ferrules DIN 46228/4, max.	2.5 mm ²
Conductor cross-section, flexible, AEH (DIN 46228-1), min.	0.25 mm ²	Conductor cross-section, flexible, AEH (DIN 46228-1), max.	2.5 mm ²
Wire connection cross section, finely stranded, two clampable wires, min.	0.5 mm ²	Wire cross-section, finely stranded, two clampable wires, max.	1 mm ²
Blade size	size PHO		

Classifications

ETIM 8.0	EC001504	ETIM 9.0	EC001504
ETIM 10.0	EC001504	ECLASS 14.0	27-37-16-04
ECLASS 15.0	27-37-16-04		

TOS 24VDC ACT

Weidmüller Interface GmbH & Co. KG
Klingenbergstraße 26
D-32758 Detmold
Germany

www.weidmueller.com

Drawings

Wiring diagram

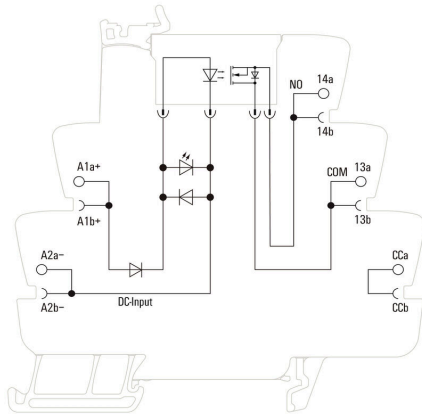

Dimensional drawing



Miscellaneous

Type code TERMSERIES solid-state relay versions



Type codes

Drawings

**Space requirement for an 8-channel system
 with a standard TERMSERIES 1CO relay**

Example of output wiring to show the difference in 8 loads to be wired:

Result width = 8 x 5.1 mm (2-pole terminal block) + 1 x 2.1 mm (end plate)
 + 8 x 6.4 mm (TRP 24VDC 1CO) + 3 x 8.0 mm (end bracket) = 118.1 mm

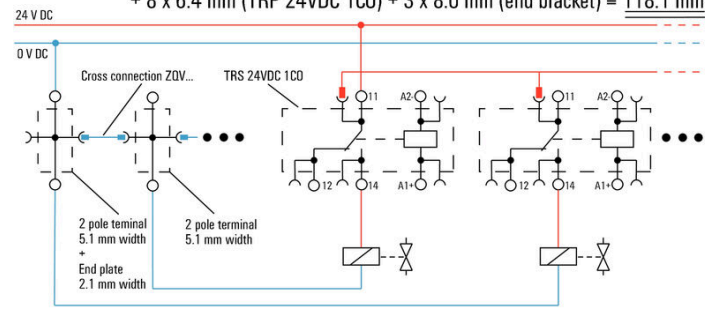

Space requirement top view:



**Space requirement for an 8-channel system
 with TERMSERIES ACT version relays and supply terminals**

Example of output wiring to show the difference in 8 loads to be wired:

Result width = 1 x 6.4 mm (TRP SUPPLY) + 8 x 6.4 mm (TRP 24VDC ACT)
 + 2 x 8.0 mm (end bracket) = 73.6 mm

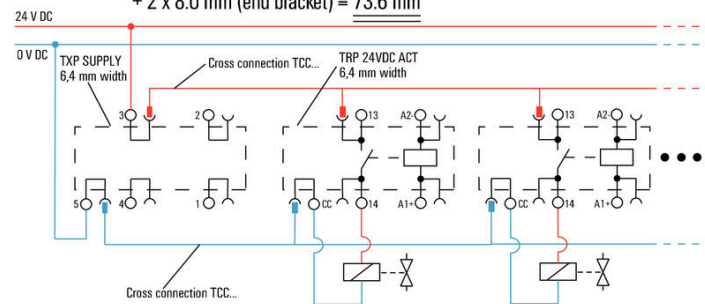

Space requirement top view:

