

UR20-4RO-SSR-255

Weidmüller Interface GmbH & Co. KG

Klingenbergstraße 26

D-32758 Detmold

Germany

www.weidmueller.com



Digital output modules P- or N-switching; short-circuit-proof; up to 3-wire + FE

Digital output modules are available in the following variants: 4 DO, 8 DO with 2- and 3-wire technology, 16 DO with or without PLC interface connection. They are mainly used for the incorporation of decentralised actuators. All outputs are designed for DC-13 actuators acc. to DIN EN 60947-5-1 and IEC 61131-2 specifications. As with the digital input modules, frequencies of up to 1 kHz are possible. Protection of the outputs ensures maximum system safety. This consists of an automatic restart following a short-circuit. Clearly visible LEDs signal the status of the entire module as well as the status of individual channels.

In addition to the standard applications of the digital output modules, the range also includes special variants such as the 4RO-SSR module for rapidly switching applications. Fitted with solid state technology, 0.5 A is available here to each output. Furthermore, there is also the 4RO-CO relay module for power-intensive applications. It is equipped with four CO contacts, optimised for a switching voltage of 255 V UC and designed for a switching current of 5 A.

The module electronics supply the connected actuators from the output current path (UOUT).

General ordering data

Version	Remote I/O module, IP20, Digital signals, Output, Relay
Order No.	1315540000
Type	UR20-4RO-SSR-255
GTIN (EAN)	4050118118445
Qty.	1 items

UR20-4RO-SSR-255

Weidmüller Interface GmbH & Co. KG
 Klingenbergstraße 26
 D-32758 Detmold
 Germany

www.weidmueller.com

Technical data

Approvals

Approvals



ROHS	Conform
UL File Number Search	UL Website
Certificate no. (cULus)	E141197
Certificate no. (cULusEX)	E223527

Dimensions and weights

Depth	76 mm	Depth (inches)	2.9921 inch
Height	120 mm	Height (inches)	4.7244 inch
Width	11.5 mm	Width (inches)	0.4528 inch
Mounting dimension - height	128 mm	Net weight	83 g

Temperatures

Storage temperature	-40 °C ... +85 °C	Operating temperature	-20 °C...60 °C
---------------------	-------------------	-----------------------	----------------

Environmental Product Compliance

RoHS Compliance Status	Compliant with exemption		
RoHS Exemption (if applicable/known)	7a, 7cI		
REACH SVHC	Lead 7439-92-1		
SCIP	82327f13-cd27-455a-ab5b-a62e1996dcf8		
Product Carbon Footprint	Cradle to gate	8,319 kg CO2 eq.	

digital outputs

Short-circuit-proof	No		
Leakage current	<1 mA		
Number	4		
Number of digital outputs	4		
Type	SSR / Triac		
Max. switching frequency	20 Hz		
Feedback-free	Yes		
Max. response time, low	10 ms		
Output current per channel, max.	1 A		
Output current per channel, min.	50 mA		
Simultaneity factor	min.	0 %	
	nominal	0 %	
	max.	0 %	
Module diagnosis	Yes		
Individual channel diagnosis	No		
Max. response time, high	10 ms		
Output current per module, max.	4 A		

UR20-4RO-SSR-255

Weidmüller Interface GmbH & Co. KG

Klingenbergstraße 26
D-32758 Detmold
Germany

www.weidmueller.com

Technical data

Switching voltage, max. 255 V AC, UL: 277 V AC

Connection data

Wire cross-section, finely stranded, max. (AWG)	AWG 16	Wire cross-section, finely stranded, min. (AWG)	AWG 26
Wire cross-section, solid, max. (AWG)	AWG 16	Wire cross-section, solid, min. (AWG)	AWG 26
Type of connection	PUSH IN	Number	4
Wire cross-section, solid, max.	1.5 mm ²	Wire cross-section, solid, min.	0.14 mm ²
Wire connection cross section, finely stranded, max.	1.5 mm ²	Wire connection cross section, finely stranded, min.	0.14 mm ²

General data

Vibration resistance	5 Hz ≤ f ≤ 8.4 Hz: 3.5-mm amplitude as per IEC 60068-2-6, 8.4 Hz ≤ f ≤ 150 Hz: 1 g acceleration as per IEC 60068-2-6	UL 94 flammability rating	V-0
Test voltage	500 V	Surge voltage category	II
Pollution severity	2	Mounting rail	TS 35
Air pressure (operation)	≥ 795 hPa (height ≤ 2000 m) as per DIN EN 61131-2	Air humidity (transport)	10% to 95%, non-condensing as per DIN EN 61131-2
Air pressure (transport)	1013 hPa (height 0 m) to 700 hPa (height 3000 m) as per DIN EN 61131-2	Air pressure (storage)	1013 hPa (height 0 m) to 700 hPa (height 3000 m) as per DIN EN 61131-2
Air humidity (operation)	10% to 95%, non-condensing as per DIN EN 61131-2	Air humidity (storage)	10% to 95%, non-condensing as per DIN EN 61131-2
Shock	15 g over 11 ms, half sinus wave, acc. to IEC 60068-2-27		

Power supply

Supply voltage	24 V DC +20 %/ -15 %, via the system bus	Current consumption from I _{sys} , typ.	8 mA
Current consumption from IO _{UT} (the respective power segment)	<15 mA		

System data

Module type	Digital output module	Interface	u-remote system bus
Galvanic isolation	500 V DC between the current paths	Process data	4 Bit
Connection type	PUSH IN	Field bus protocol	PROFINET IRT, PROFINET RT, PROFIBUS DP-V1, EtherCAT, Modbus/TCP, EtherNet/IP, CANopen, DeviceNet, POWERLINK, CC-Link, CC-Link IE TSN, IEC 61162-450
Possible connection	Single-conductor, 2-wire	Transmission speed of system bus, max.	48 MBit/s
Diagnostic data	1 Bit		

Classifications

ETIM 8.0	EC001599	ETIM 9.0	EC001599
ETIM 10.0	EC001599	ECLASS 14.0	27-24-26-04
ECLASS 15.0	27-24-26-04		

UR20-4RO-SSR-255

Weidmüller Interface GmbH & Co. KG
 Klingenbergstraße 26
 D-32758 Detmold
 Germany

www.weidmueller.com

Drawings

Block diagram

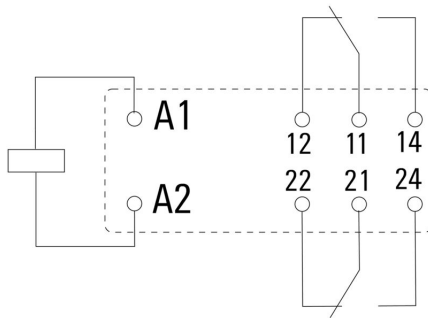

Connection diagram

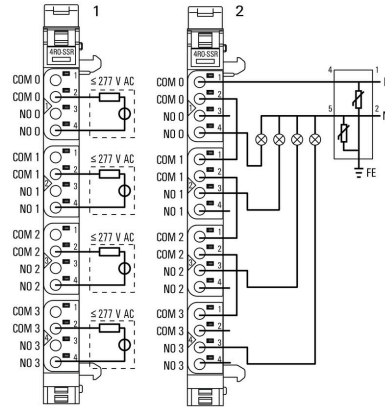

Explanation of abbreviations

Digital output modules

