

VSSC6SL LD24VAC/DC0.5A

Weidmüller Interface GmbH & Co. KG

Klingenbergstraße 26

D-32758 Detmold

Germany

www.weidmueller.com

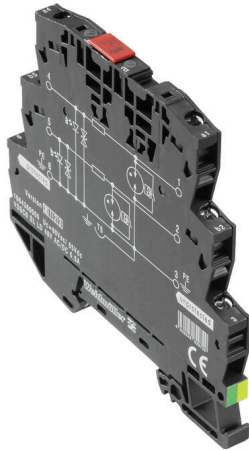

Overvoltage coupling along the conductor path may disturb or destroy sensitive signal inputs. It is important to provide protection in the immediate vicinity of I&C devices. Weidmüller's broad product range for the I&C sector offers products in a 2-piece, pluggable design and modular terminals for tension clamp or screw connection. These products are suitable for both binary and analogue signals. Weidmüller also offers other designs with integrated components such as gas discharge tubes or varistors. VARITECTOR stands for flexible and variable surge protection by Weidmüller, tested according to product standard IEC61643-21. The VARITECTOR series can be used in applications according to IEC 61643-22 / VDE 0845-3 for classes C1, C2, C3 and D1. The VARITECTOR SPC, SSC and MCZ OVP product families optimally combine electrical and mechanical properties. Size and easy handling play an important role. This surge protection is suited for confined spaces in industrial and process automation as well as in building automation applications.

General ordering data

Version	Surge protection for instrumentation and control, Surge protection for measurement and control
Order No.	1064350000
Type	VSSC6SL LD24VAC/DC0.5A
GTIN (EAN)	4032248829712
Qty.	10 items

VSSC6SL LD24VAC/DC0.5A

Weidmüller Interface GmbH & Co. KG

Klingenbergstraße 26

D-32758 Detmold

Germany

www.weidmueller.com

Technical data

Approvals

Approvals



ROHS Conform

UL File Number Search [UL Website](#)

Certificate No. (UL) E311081

Dimensions and weights

Depth	81 mm	Depth (inches)	3.189 inch
Height	88.5 mm	Height (inches)	3.4842 inch
Width	6.2 mm	Width (inches)	0.2441 inch
Net weight	41.6 g		

Temperatures

Storage temperature	-40 °C...80 °C	Ambient temperature	-40 °C...70 °C
Operating temperature	-40 °C...70 °C	Humidity	5...96 %

Probability of failure

SIL in compliance with IEC 61508	3	MTTF	2114 a
SFF	96.67 %	λges	54
PFH in 1*10 ⁻⁹ per hour	1.8		

Environmental Product Compliance

RoHS Compliance Status	Compliant with exemption
RoHS Exemption (if applicable/known)	7a, 7cl
REACH SVHC	Lead 7439-92-1
SCIP	71e97bb7-979f-4330-94c0-20c629bb05e3

Rated data UL

Certificate No. (UL)	E311081	UL certificate	UL Zertifikat - PDF/ E311081VOL1SEC3.pdf (application/pdf)
----------------------	---------	----------------	--

CSA protection data

Gas group D	IIA	Gas groups A, B	IIC
Input-current, max. II	500 mA	Gas group C	IIB
Internal inductance, max. LI	0 µH	Internal capacity, max. CI	2 nF
Input voltage, max. Ui	42 V		

General data

Optical function display	Yes	Segment	Measurement - Monitoring - Setting
Version	Surge protection for measurement and control	Design	Terminal
UL 94 flammability rating	V-0	Colour	black
Protection degree	IP20	Mounting rail	TS 35
Isolating function	No		

VSSC6SL LD24VAC/DC0.5A

Weidmüller Interface GmbH & Co. KG
 Klingenbergstraße 26
 D-32758 Detmold
 Germany

www.weidmueller.com

Technical data

Insulation coordination acc. to EN 50178

Surge voltage category	III	Pollution severity	2
------------------------	-----	--------------------	---

Rated data IEC / EN

Number of poles	1	Leakage current at Un	2.8 mA
Signalling contact	No	Rated voltage (AC)	24 V
Rated voltage (DC)	34 V	Rated current IN	500 mA
Protection level, UP wire - wire	150 V	Protection level, UP wire - PE	150 V
Voltage type	AC/DC	Fuse protection	0.5 A
Volume resistance	1.8 Ω 10 %	Frequency range, max.	3.2 MHz
Standards	IEC 61643-21	Lightning test current limp (10/350 μs)	1 kA
Discharge current, max. (8/20 μs)	20 kA	Requirements category acc. to IEC 61643-21	C2, C3, D1
Insertion loss	3.12 Mhz	Max. continuous voltage, Uc (AC)	30 V
Max. continuous voltage, Uc (DC)	42 V	Surge current-carrying capacity D1	1 kA 10/350 μs
Surge current-carrying capacity C3	10 A 10/1000 μs	Pulse-reset capacity	≤ 20 ms
Signal transmission properties (-3 dB)	3.2 MHz	Lightning test current, limp (10/350 μs) Wire-PE	1 kA
Overload - failure mode	Modus 2	Rated load current IL	500 mA
Discharge current In (8/20μs) wire-PE	2.5 kA	Discharge current I _{max} (8/20μs) wire-PE	10 kA
Surge current-carrying capacity C2	2.5 kA 8/20 μs		

Further details of approvals

GOST certificate	GOST-Zertifikat - PDF/7950_n1-n4.pdf (application/pdf)
------------------	--

Connection data

Stripping length	10 mm	Type of connection	Screw connection
Tightening torque, min.	0.5 Nm	Tightening torque, max.	0.8 Nm
Clamping range, min.	0.5 mm ²	Clamping range, max.	4 mm ²
Wire cross-section, solid, min.	0.5 mm ²	Wire cross-section, solid, max.	6 mm ²
Conductor cross-section, flexible, AEH (DIN 46228-1), min.	0.5 mm ²	Conductor cross-section, flexible, AEH (DIN 46228-1), max.	4 mm ²
Connection cross-section, stranded, min.	0.5 mm ²	Connection cross-section, stranded, max.	4 mm ²

Electrical data

Voltage type	AC/DC
--------------	-------

General data

Number of poles	1	Protection degree	IP20
Colour	black		

Ratings IECEx/ATEX/cUL

cUL certificate	cUL Certificate - pdf/ VSSC.PDF (application/pdf)
-----------------	---

VSSC6SL LD24VAC/DC0.5A

Weidmüller Interface GmbH & Co. KG
Klingenbergstraße 26
D-32758 Detmold
Germany

www.weidmueller.com

Technical data**Important note**

Product information Mode 2: State where the voltage-limiting part of the SPD was short-circuited due to a very low impedance within the SPD. The line is inoperable, but the measuring equipment is still protected by means of a short-circuit.

Classifications

ETIM 8.0	EC000943	ETIM 9.0	EC000943
ETIM 10.0	EC000943	ECLASS 14.0	27-17-15-01
ECLASS 15.0	27-17-15-01		

VSSC6SL LD24VAC/DC0.5A

Weidmüller Interface GmbH & Co. KG
Klingenbergstraße 26
D-32758 Detmold
Germany

Drawings

www.weidmueller.com

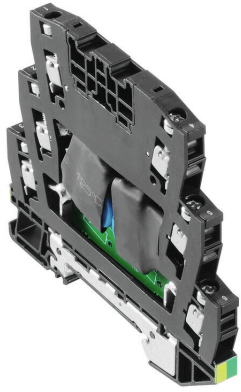

Similar to illustration

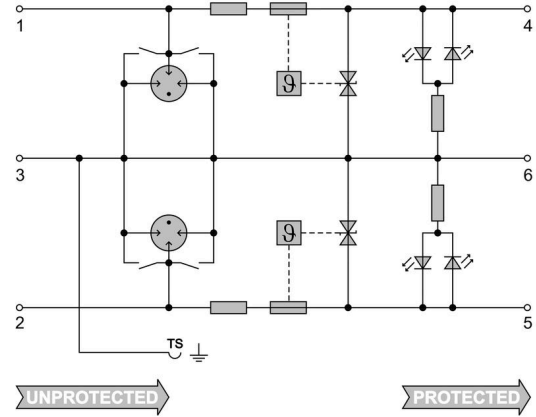

Circuit diagram

