

**SL-SMT 5.08HC/11/90LF 3.2SN BK BX SO**

**Weidmüller Interface GmbH & Co. KG**  
 Klingenbergstraße 26  
 D-32758 Detmold  
 Germany

www.weidmueller.com



Similar to illustration

High-temperature-resistant pin header, packed in box or tape. On tape, with 1.5 mm solder pin, optimised for automatic assembly. 3.2 mm solder pin suitable for reflow and wave soldering. The pin headers provide space for labelling and can be coded. HC = High Current.

**General ordering data**

|              |  |
|--------------|--|
| Version      | PCB plug-in connector, male header, Solder flange, THT/THR solder connection, 5.08 mm, Number of poles: 11, 90°, Solder pin length (l): 3.2 mm, tinned, black, Box |
| Order No.    | <a href="#">1007050000</a>   |
| Type         | SL-SMT 5.08HC/11/90LF 3.2SN BK BX SO   |
| GTIN (EAN)   | 4032248708598  |
| Qty.         | 24 items   |
| Product data | IEC: 400 V / 27.5 A<br>UL: 300 V / 18.5 A  |
| Packaging    | Box  |

Creation date 12.03.2026 07:31:14 MEZ

Catalogue status / Drawings

## SL-SMT 5.08HC/11/90LF 3.2SN BK BX SO

Weidmüller Interface GmbH & Co. KG  
Klingenbergstraße 26  
D-32758 Detmold  
Germany

www.weidmueller.com

## Technical data

## Approvals

Approvals



|                       |                            |
|-----------------------|----------------------------|
| ROHS                  | Conform                    |
| UL File Number Search | <a href="#">UL Website</a> |
| Certificate No. (UR)  | E60693                     |

## Dimensions and weights

|                          |             |                 |             |
|--------------------------|-------------|-----------------|-------------|
| Depth                    | 12 mm       | Depth (inches)  | 0.4724 inch |
| Height                   | 11.7 mm     | Height (inches) | 0.4606 inch |
| Height of lowest version | 8.5 mm      | Width           | 65.68 mm    |
| Width (inches)           | 2.5858 inch | Net weight      | 6.06 g      |

## Environmental Product Compliance

|                          |                             |                  |  |
|--------------------------|-----------------------------|------------------|--|
| RoHS Compliance Status   | Compliant without exemption |                  |  |
| REACH SVHC               | No SVHC above 0.1 wt%       |                  |  |
| Product Carbon Footprint | Cradle to gate              | 0,147 kg CO2 eq. |  |

## System specifications

|  |                                     |  |   |
|--|-------------------------------------|--|---|
| Product family                             | OMNIMATE Signal - series BL/SL 5.08 | Type of connection                           | Board connection                                    |
| Mounting onto the PCB                      | THT/THR solder connection           | Pitch in mm (P)                              | 5.08 mm   |
| Pitch in inches (P)                        | 0.200 "                             | Outgoing elbow                               | 90°   |
| Number of poles                            | 11                                  | Number of solder pins per pole               | 1   |
| Solder pin length (l)                      | 3.2 mm                              | Solder pin length tolerance                  | 0 / -0.3 mm   |
| Solder pin dimensions                      | d = 1.2 mm, Octagonal               | L1 in mm                                     | 50.80 mm  |
| L1 in inches                               | 2.000 "                             | Number of rows                               | 1   |
| Pin series quantity                        | 1                                   | Touch-safe protection acc. to DIN VDE 57 106 | finger-safe unplugged/<br>back-of-hand-safe plugged |
| Touch-safe protection acc. to DIN VDE 0470 | IP20 plugged/ IP10 unplugged        | Protection degree                            | IP20  |
| Volume resistance                          | ≤5 mΩ                               | Can be coded                                 | Yes   |
| Plugging force/pole, max.                  | 9 N                                 | Pulling force/pole, max.                     | 7 N   |

## Material data

|                                       |                                |                                       |                                |
|---------------------------------------|--------------------------------|---------------------------------------|--------------------------------|
| Insulating material                   | LCP GF                         | Colour                                | black                          |
| Colour chart (similar)                | RAL 9011                       | Insulating material group             | IIIa                           |
| Comparative Tracking Index (CTI)      | ≥ 175                          | Moisture Level (MSL)                  | 1                              |
| UL 94 flammability rating             | V-0                            | Contact material                      | Cu-alloy                       |
| Contact surface                       | tinned                         | Layer structure of solder connection  | 1...3 μm Ni / 2...4 μm Sn matt |
| Layer structure of plug contact       | 1...3 μm Ni / 2...4 μm Sn matt | Storage temperature, min.             | -40 °C                         |
| Storage temperature, max.             | 70 °C                          | Operating temperature, min.           | -50 °C                         |
| Operating temperature, max.           | 100 °C                         | Temperature range, installation, min. | -30 °C                         |
| Temperature range, installation, max. | 100 °C                         |                                       |                                |

## SL-SMT 5.08HC/11/90LF 3.2SN BK BX SO

Weidmüller Interface GmbH &amp; Co. KG

Klingenbergstraße 26

D-32758 Detmold

Germany

www.weidmueller.com

## Technical data

## Rated data acc. to IEC

|   |                        |   |        |
|---|------------------------|---|--------|
| tested acc. to standard   | IEC 60664-1, IEC 61984 | Rated current, min. number of poles (Tu=20°C)                         | 27.5 A |
| Rated current, max. number of poles (Tu=20°C)                             | 19 A                   | Rated current, min. number of poles (Tu=40°C)                         | 24 A   |
| Rated current, max. number of poles (Tu=40°C)                             | 16.5 A                 | Rated voltage for surge voltage class / pollution degree II/2         | 400 V  |
| Rated voltage for surge voltage class / pollution degree III/2            | 320 V                  | Rated voltage for surge voltage class / pollution degree III/3        | 250 V  |
| Rated impulse voltage for surge voltage class/ pollution degree II/2      | 4 kV                   | Rated impulse voltage for surge voltage class/ pollution degree III/2 | 4 kV   |
| Rated impulse voltage for surge voltage class/ contamination degree III/3 | 4 kV                   |   |        |

## Rated data acc. to CSA

|                                   |        |                                   |        |
|-----------------------------------|--------|-----------------------------------|--------|
| Rated voltage (Use group B / CSA) | 300 V  | Rated voltage (Use group D / CSA) | 300 V  |
| Rated current (Use group B / CSA) | 18.5 A | Rated current (Use group D / CSA) | 18.5 A |

## Rated data acc. to UL 1059

|                                       |  |                                       |        |
|---------------------------------------|--|---------------------------------------|--------|
| Institute (UR)                        | UR   | Certificate No. (UR)                  | E60693 |
| Rated voltage (Use group B / UL 1059) | 300 V  | Rated voltage (Use group D / UL 1059) | 300 V  |
| Rated current (Use group B / UL 1059) | 18.5 A   | Rated current (Use group D / UL 1059) | 10 A   |
| Reference to approval values          | Specifications are maximum values, details - see approval certificate. |                                       |        |

## Packing

|           |           |            |           |
|-----------|-----------|------------|-----------|
| Packaging | Box       | VPE length | 339.00 mm |
| VPE width | 134.00 mm | VPE height | 21.00 mm  |

## Important note

IPC conformity: Conformity: The products are developed, manufactured and delivered according international recognized standards and norms and comply with the assured properties in the data sheet resp. fulfill decorative properties in accordance with IPC-A-610 "Class 2". Further claims on the products can be evaluated on request.

Notes

- Gold-plated contact surfaces on request
- Rated current related to rated cross-section & min. No. of poles.
- Diameter of solder eyelet D = 1.4+0.1mm
- Solder eyelet diameter D = 1.5 + 0.1 mm, from 9 poles
- P on drawing = pitch
- Rated data refer only to the component itself. Clearance and creepage distances to other components are to be designed in accordance with the relevant application standards.
- In accordance with IEC 61984, OMNIMATE-connectors are connectors without breaking capacity (COC). During designated use, connectors are not allowed to be engaged or disengaged when live or under load
- Long term storage of the product with average temperature of 50 °C and maximum humidity 70%, 36 months

## Classifications

|             |             |             |             |
|-------------|-------------|-------------|-------------|
| ETIM 8.0    | EC002637    | ETIM 9.0    | EC002637    |
| ETIM 10.0   | EC002637    | ECLASS 14.0 | 27-46-02-01 |
| ECLASS 15.0 | 27-46-02-01 |             |             |

Dimensional drawing

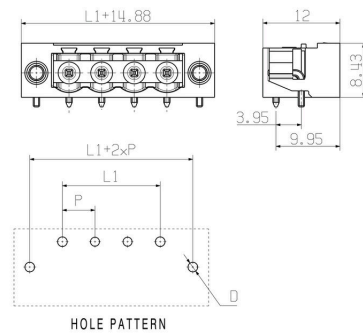

Product benefits



Safe power transmission Proven properties