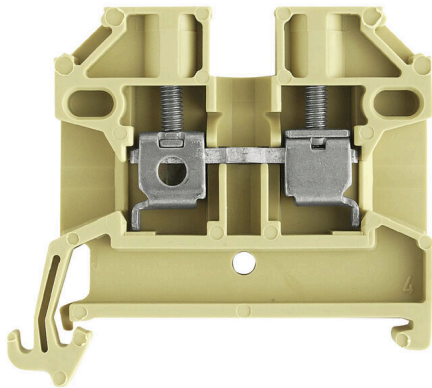

**SAK 2.5/35****Weidmüller Interface GmbH & Co. KG**Klingenbergstraße 26  
D-32758 Detmold  
Germany

www.weidmueller.com

**Product image**

To feed through power, signal, and data is the classical requirement in electrical engineering and panel building. The insulating material, the connection system and the design of the terminal blocks are the differentiating features. A feed-through terminal block is suitable for joining and/or connecting one or more conductors. They could have one or more connection levels that are on the same potential or insulated against one another.

**General ordering data**

Version	Feed-through terminal block, Screw connection, beige / yellow, 2.5 mm <sup>2</sup> , 24 A, 800 V, Number of connections: 2
Order No.	<a href="#">0380460000</a>
Type	SAK 2.5/35
GTIN (EAN)	4008 190042363
Qty.	100 items
Alternative product	<a href="#">WDU 2.5</a>

## SAK 2.5/35

**Weidmüller Interface GmbH & Co. KG**  
 Klingenbergstraße 26  
 D-32758 Detmold  
 Germany

www.weidmueller.com

## Technical data

### Approvals

Approvals



ROHS	Conform
UL File Number Search	<a href="#">UL Website</a>
Certificate No. (UR)	E60693

### Dimensions and weights

Depth	40 mm	Depth (inches)	1.5748 inch
Height	44.5 mm	Height (inches)	1.752 inch
Width	6.1 mm	Width (inches)	0.2402 inch
Net weight	6.33 g		

### Temperatures

Storage temperature	-25 °C...55 °C	Ambient temperature	-50 °C...55 °C
Continuous operating temp., min.	-50 °C	Continuous operating temp., max.	100 °C

### Environmental Product Compliance

RoHS Compliance Status	Compliant without exemption
REACH SVHC	No SVHC above 0.1 wt%

### Material data

Basic material	PA 66	Colour	beige / yellow
UL 94 flammability rating	V-2		

### Rating data IECEX/ATEX

Certificate No. (ATEX)	TUEV18ATEX8207U	Certificate No. (IECEX)	IECEXTUR18.0017U
Max. voltage (ATEX)	690 V	Current (ATEX)	24 A
Wire cross section max. (ATEX)	6 mm <sup>2</sup>	Max. voltage (IECEX)	690 V
Current (IECEX)	24 A	Wire cross section max. (IECEX)	6 mm <sup>2</sup>
Marking EN 60079-7	Ex eb II C Gb	Ex 2014/34/EU label	II 2 G D

### System specifications

Version	Screw connection, for screwable cross-connection, One end without connector	End cover plate required	Yes
Number of potentials	1	Number of levels	1
Number of clamping points per level	2	Number of potentials per tier	1
Levels cross-connected internally	No	PE connection	No
Mounting rail	TS 35	N-function	No
PE function	No	PEN function	No

## SAK 2.5/35

Weidmüller Interface GmbH &amp; Co. KG

Klingenbergstraße 26

D-32758 Detmold

Germany

www.weidmueller.com

## Technical data

## Additional technical data

Open sides	right	Number of similar terminals	1
Installation advice	Direct mounting	Explosion-tested version	Yes
Type of mounting	Snap-on		

## CSA rating data

Wire cross section max. (CSA)	10 AWG	Voltage size C (CSA)	600 V
Current size C (CSA)	25 A	Certificate No. (CSA)	12400-129
Wire cross section min. (CSA)	26 AWG		

## Conductors for clamping (additional connection)

Conductor cross-section, flexible plus plastic collar DIN 46228/1, further connection, max.	4 mm <sup>2</sup>	Connection type, additional connection	Screw connection
---------------------------------------------------------------------------------------------	-------------------	----------------------------------------	------------------

## Conductors for clamping (rated connection)

Gauge to IEC 60947-1	A3	Wire connection cross section AWG, max.	AWG 14
Connection direction	on side	Tightening torque, max.	0.8 Nm
Tightening torque, min.	0.4 Nm	Stripping length	10 mm
Type of connection	Screw connection	Number of connections	2
Clamping range, max.	6 mm <sup>2</sup>	Clamping range, min.	0.13 mm <sup>2</sup>
Clamping screw	M 2.5	Blade size	0.6 x 3.5 mm
Wire connection cross section AWG, min.	AWG 26	Wire connection cross-section, finely stranded with wire-end ferrules DIN 46228/4, max.	4 mm <sup>2</sup>
Wire connection cross-section, finely stranded with wire-end ferrules DIN 46228/4, min.	0.13 mm <sup>2</sup>	Wire connection cross-section, finely stranded with wire-end ferrules DIN 46228/1, max.	4 mm <sup>2</sup>
Wire connection cross-section, finely stranded with wire-end ferrules DIN 46228/1, min.	0.13 mm <sup>2</sup>	Wire connection cross section, finely stranded, max.	4 mm <sup>2</sup>
Wire connection cross section, finely stranded, min.	0.13 mm <sup>2</sup>	Connection cross-section, stranded, max.	4 mm <sup>2</sup>
Connection cross-section, stranded, min.	0.13 mm <sup>2</sup>	Twin wire-end ferrules, max.	1.5 mm <sup>2</sup>
Twin wire-end ferrules, min.	0.5 mm <sup>2</sup>	Torque level with DMS electric screwdriver	1
Wire connection cross-section, solid core, max.	6 mm <sup>2</sup>	Wire connection cross-section, solid core, min.	0.13 mm <sup>2</sup>
Connection cross-section, finely stranded, min.	0.13 mm <sup>2</sup>		

## General

Wire connection cross section AWG, max.	AWG 14	Installation advice	Direct mounting
Wire connection cross section AWG, min.	AWG 26	Standards	IEC 60947-7-1
Mounting rail	TS 35		

## Rating data

Rated cross-section	2.5 mm <sup>2</sup>	Rated voltage	800 V
Rated DC voltage	800 V	Nominal current	24 A

## SAK 2.5/35

**Weidmüller Interface GmbH & Co. KG**

Klingenbergstraße 26  
D-32758 Detmold  
Germany

[www.weidmueller.com](http://www.weidmueller.com)

## Technical data

Current at maximum wires	41 A	Standards	IEC 60947-7-1
Volume resistance according to IEC 60947-7-x	1.33 mΩ	Rated impulse withstand voltage	8 kV
Power loss in accordance with IEC 60947-7-x	0.77 W	Pollution severity	3

## UL rating data

Conductor size Factory wiring max. (UR)	12 AWG	Current size C (UR)	20 A
Voltage size C (UR)	600 V	Conductor size Factory wiring min. (UR)	22 AWG
Certificate No. (UR)	E60693	Conductor size Field wiring min. (UR)	22 AWG
Conductor size Field wiring max. (UR)	12 AWG		

## Classifications

ETIM 8.0	EC000897	ETIM 9.0	EC000897
ETIM 10.0	EC000897	ECLASS 14.0	27-25-01-01
ECLASS 15.0	27-25-01-01		